

UHF FM TRANSCEIVER

# TK-8360/8360H TK-8360H(U)

## SERVICE MANUAL

# KENWOOD

Kenwood Corporation

© 2011-1 PRINTED IN JAPAN  
B51-8953-10 (N) PDF

**REVISED**

This service manual added the details of the panel tuning mode to B51-8953-00.

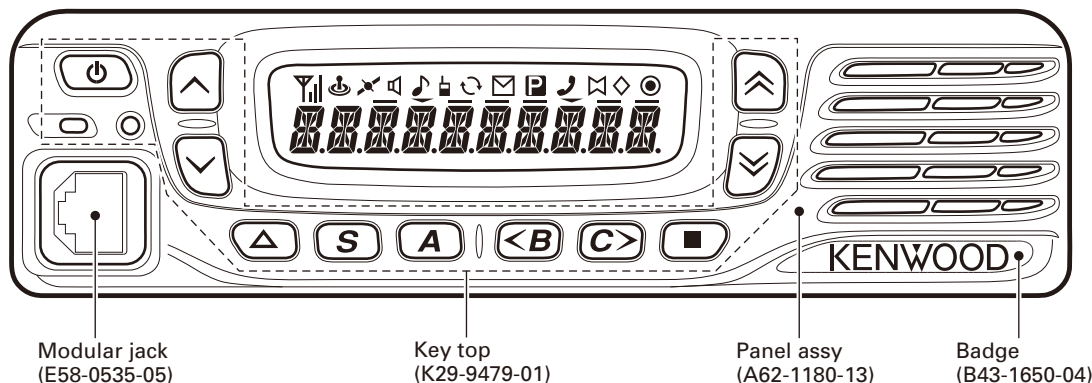

Modular jack  
(E58-0535-05)

Key top  
(K29-9479-01)

Panel assy  
(A62-1180-13)

Badge  
(B43-1650-04)

## CONTENTS

<b>GENERAL</b> .....	<b>2</b>	<b>PACKING</b> .....	<b>32</b>
<b>SYSTEM SET-UP</b> .....	<b>4</b>	<b>ADJUSTMENT</b> .....	<b>33</b>
<b>REALIGNMENT</b> .....	<b>4</b>	<b>TERMINAL FUNCTION</b> .....	<b>42</b>
<b>INSTALLATION</b> .....	<b>6</b>	<b>PC BOARD</b>	
<b>DISASSEMBLY FOR REPAIR</b> .....	<b>11</b>	<b>DISPLAY UNIT (X54-3740-20)</b> .....	<b>44</b>
<b>CIRCUIT DESCRIPTION</b> .....	<b>13</b>	<b>TX-RX UNIT (X57-8020-XX)</b> .....	<b>46</b>
<b>SEMICONDUCTOR DATA</b> .....	<b>18</b>	<b>SCHEMATIC DIAGRAM</b> .....	<b>50</b>
<b>COMPONENTS DESCRIPTION</b> .....	<b>19</b>	<b>BLOCK DIAGRAM</b> .....	<b>56</b>
<b>PARTS LIST</b> .....	<b>21</b>	<b>LEVEL DIAGRAM</b> .....	<b>58</b>
<b>EXPLODED VIEW</b> .....	<b>31</b>	<b>SPECIFICATIONS</b> .....	<b>59</b>



## Document Copyrights

Copyright 2011 by Kenwood Corporation. All rights reserved.

No part of this manual may be reproduced, translated, distributed, or transmitted in any form or by any means, electronic, mechanical, photocopying, recording, or otherwise, for any purpose without the prior written permission of Kenwood.

## Disclaimer

While every precaution has been taken in the preparation of this manual, Kenwood assumes no responsibility for errors or omissions. Neither is any liability assumed for damages resulting from the use of the information contained herein. Kenwood reserves the right to make changes to any products herein at any time for improvement purposes.

# GENERAL

## INTRODUCTION

### SCOPE OF THIS MANUAL

This manual is intended for use by experienced technicians familiar with similar types of commercial grade communications equipment. It contains all required service information for the equipment and is current as of the publication date. Changes which may occur after publication are covered by either Service Bulletins or Manual Revisions. These are issued as required.

## ORDERING REPLACEMENT PARTS

When ordering replacement parts or equipment information, the full part identification number should be included. This applies to all parts : components, kits, or chassis. If the part number is not known, include the chassis or kit number of which it is a part, and a sufficient description of the required component for proper identification.

## PERSONAL SAFETY

The following precautions are recommended for personal safety:

- DO NOT transmit if someone is within two feet (0.6 meter) of the antenna.
- DO NOT transmit until all RF connectors are secure and any open connectors are properly terminated.
- SHUT OFF this equipment when near electrical blasting caps or while in an explosive atmosphere.
- All equipment should be properly grounded before power-up for safe operation.
- This equipment should be serviced by only qualified technicians.

## PRE-INSTALLATION CONSIDERATIONS

### 1. UNPACKING

Unpack the radio from its shipping container and check for accessory items. If any item is missing, please contact KENWOOD immediately.

### 2. LICENSING REQUIREMENTS

Federal regulations require a station license for each radio installation (mobile or base) be obtained by the equipment owner. The licensee is responsible for ensuring transmitter power, frequency, and deviation are within the limits permitted by the station license.

Transmitter adjustments may be performed only by a licensed technician holding an FCC first, second or general class commercial radiotelephone operator's license. There is no license required to install or operate the radio.

### 3. PRE-INSTALLATION CHECKOUT

#### 3-1. Introduction

Each radio is adjusted and tested before shipment. However, it is recommended that receiver and transmitter operation be checked for proper operation before installation.

#### 3-2. Testing

The radio should be tested complete with all cabling and accessories as they will be connected in the final installation. Transmitter frequency, deviation, and power output should be checked, as should receiver sensitivity, squelch operation, and audio output. Signalling equipment operation should be verified.

## GENERAL

### 4. PLANNING THE INSTALLATION

#### 4-1. General

Inspect the vehicle and determine how and where the radio antenna and accessories will be mounted.

Plan cable runs for protection against pinching or crushing wiring, and radio installation to prevent overheating.

#### 4-2. Antenna

The favored location for an antenna is in the center of a large, flat conductive area, usually at the roof center. The trunk lid is preferred, bond the trunk lid and vehicle chassis using ground straps to ensure the lid is at chassis ground.

#### 4-3. Radio

The universal mount bracket allows the radio to be mounted in a variety of ways. Be sure the mounting surface is adequate to support the radio's weight. Allow sufficient space around the radio for air cooling. Position the radio close enough to the vehicle operator to permit easy access to the controls when driving.

#### 4-4. DC Power and wiring

1. This radio may be installed in negative ground electrical systems only. Reverse polarity will cause the cable fuse to blow. Check the vehicle ground polarity before installation to prevent wasted time and effort.
2. Connect the positive power lead directly to the vehicle battery positive terminal. Connecting the Positive lead to any other positive voltage source in the vehicle is not recommended.
3. Connect the ground lead directly to the battery negative terminal.
4. The cable provided with the radio is sufficient to handle the maximum radio current demand. If the cable must be extended, be sure the additional wire is sufficient for the current to be carried and length of the added lead.

### 5. INSTALLATION PLANNING – CONTROL STATIONS

#### 5-1. Antenna system

Control station. The antenna system selection depends on many factors and is beyond the scope of this manual. Your KENWOOD dealer can help you select an antenna system that will best serve your particular needs.

#### 5-2. Radio location

Select a convenient location for your control station radio which is as close as practical to the antenna cable entry point. Secondly, use your system's power supply (which supplies the voltage and current required for your system). Make sure sufficient air can flow around the radio and power supply to allow adequate cooling.

## SERVICE

This radio is designed for easy servicing. Refer to the schematic diagrams, printed circuit board views, and alignment procedures contained in this manual.

## NOTE

If you do not intend to use the speaker 3.5-mm jack and the D-sub 15-pin connector, fit the supplied speaker-jack cap and ACC cap to stop dust and sand from getting in.

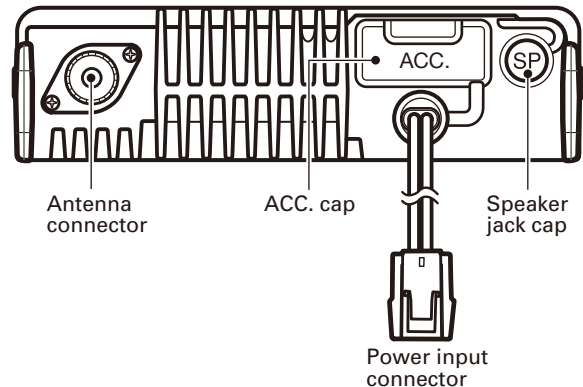

## SYSTEM SET-UP

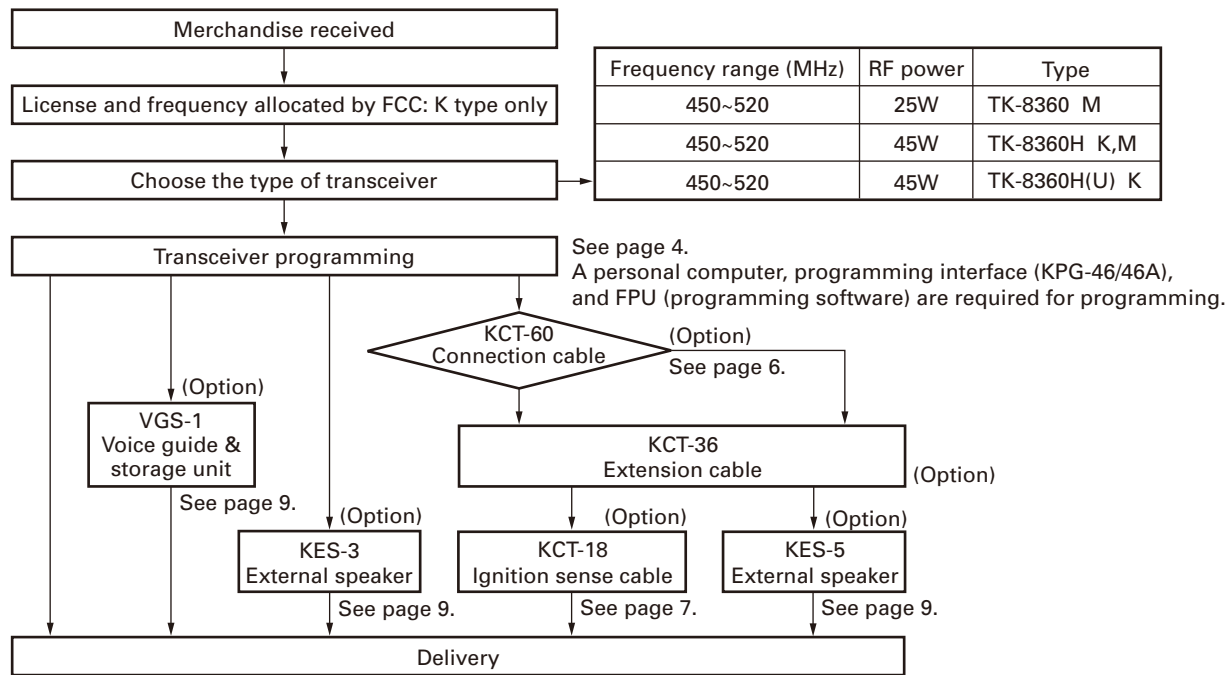

## REALIGNMENT

### 1. Modes

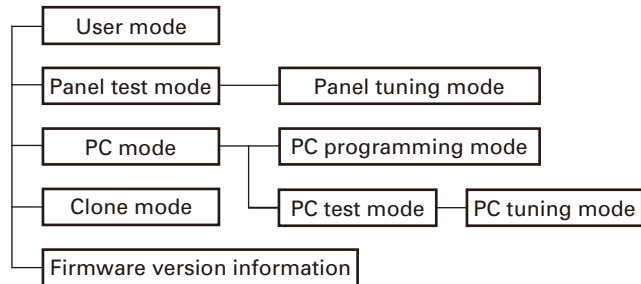

Mode	Function
User mode	For normal use.
Panel test mode	Use by the dealer to check the fundamental characteristics.
Panel tuning mode	Used by the dealer to tune the transceiver.
PC mode	Used for communication between the transceiver and PC.
PC programming mode	Used to read and write frequency data and other features to and from the transceiver.
PC test mode	Used to check the transceiver using the PC. This feature is included in the FPU.
PC tuning mode	Used to tune the transceiver using the PC.
Clone mode	Used to transfer programming data from one transceiver to another.
Firmware version information	Used to confirm the internal firmware version.

### 2. How to Enter Each Mode

Mode	Operation
User mode	Power ON
Panel test mode	[A]+Power ON
Panel tuning mode	Panel test mode+[S]
PC mode	Received commands from PC
Clone mode	[<B]+Power ON (One second)
Firmware version information	[Δ]+Power ON

### 3. Panel Test Mode

Setting method refer to ADJUSTMENT.

### 4. Panel Tuning Mode

Setting method refer to ADJUSTMENT.

### 5. PC Mode

#### 5-1. Preface

The transceiver is programmed using a personal computer, a programming interface (KPG-46/46A, USB adapter (KCT-53U)) and FPU (programming software).

The programming software can be used with a PC. Figure 1 shows the setup of a PC for programming.

## REALIGNMENT

### 5-2. Connection procedure

1. Connect the transceiver to the computer using the interface cable and USB adapter (When the interface cable is KPG-46A, the KCT-53U can be used.).

#### Note:

- You must install the KCT-53U driver in the computer to use the USB adapter (KCT-53U).
  - When using the USB adapter (KCT-53U) for the first time, plug the KCT-53U into a USB port on the computer with the computer power ON.
2. When the Power is switched on, user mode can be entered immediately. When the PC sends a command, the transceiver enters PC mode, and "PROGRAM" is displayed on the LCD.  
When data is transmitting from the transceiver, the red LED blinks.  
When data is receiving by the transceiver, the green LED blinks.

#### Note:

The data stored in the computer must match the "Model Name" when it is written into the EEPROM.

### 5-3. KPG-46/KPG-46A description

#### (PC programming interface cable: Option)

The KPG-46/46A is required to interface the transceiver to the computer. It has a circuit in its D-sub connector (KPG-46: 25-pin, KPG-46A: 9-pin) case that converts the RS-232C logic level to the TTL level.

The KPG-46/46A connects the 8-pin microphone connector of the transceiver to the RS-232C serial port of the computer.

### 5-4. KCT-53U description (USB adapter: Option)

The KCT-53U is a cable which connects the KPG-46A to a USB port on a computer.

When using the KCT-53U, install the supplied CD-ROM (with driver software) in the computer. The KCT-53U driver runs under Windows 2000, XP or Vista (32-bit).

### 5-5. FPU (Programming Software) description

The FPU is the programming software for the transceiver supplied on a CD-ROM. This software runs under Windows XP, Vista or 7 on a PC.

The data can be input to or read from the transceiver and edited on the screen. The programmed or edited data can be printed out. It is also possible to tune the transceiver.

#### List of FPU for transceiver

Model	Type	FPU
TK-8360	M	KPG-135D(M)
TK-8360H	K	KPG-135D(K)
TK-8360H	M	KPG-135D(M)
TK-8360H(U)	K	KPG-135D(K)

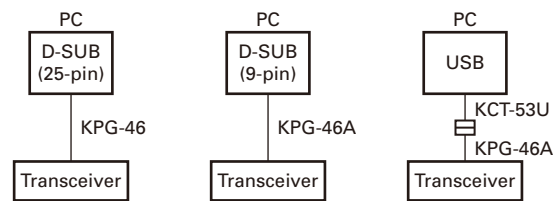
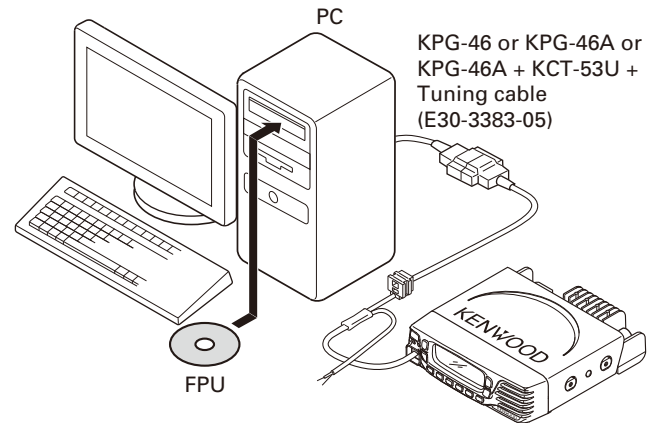

Fig. 1

## 6. Clone Mode

Programming data can be transferred from one transceiver to another by connecting them via their modular microphone jacks. The operation is as follows (the transmit transceiver is the source and the receive transceiver is a target).

#### Note :

Clone mode should be enabled.

1. Turn the source transceiver power ON with the [**B**] key held down (1 second), "CLONE MODE" is displayed on the LCD.
2. Power on the target transceiver.
3. Connect the cloning cable (No. E30-3382-05) to the modular microphone jacks on the source and target.
4. Press the [**S**] key on the source transceiver.  
The data of the source is sent to the target. While the source is sending data, red LED blinks. While the target is receiving the data, "PROGRAM" is displayed and green LED blinks. When cloning of data is completed, the source displays "END", and the source red LED turned off, and the target automatically operates in the User mode. The target can then be operated by the same program as the source.
5. The other target can be continuously cloned. Carry out the operation in step 2 to 4.

## REALIGNMENT

### 6-1. Adding the data password

If the read authorization password is set in the optional feature menu, you must enter the password (Source transceiver) to activate a clone mode.

You can use 0~9 to configure the password. The maximum length of the password is 6 digits.

1. [**B**]+Power ON.
2. "CLONE LOCK" is displayed on the LCD.
3. If the [**↵**] and [**↶**] keys is pressed while "CLONE LOCK" is displayed, numbers (0 to 9) are displayed flashing. When you press the [**C>**] key, the currently selected number is determined. If you press the [**S**] key after entering the password in this procedure, "CLONE MODE" is displayed if the entered password is correct. If the password is incorrect, "CLONE LOCK" is redisplayed.

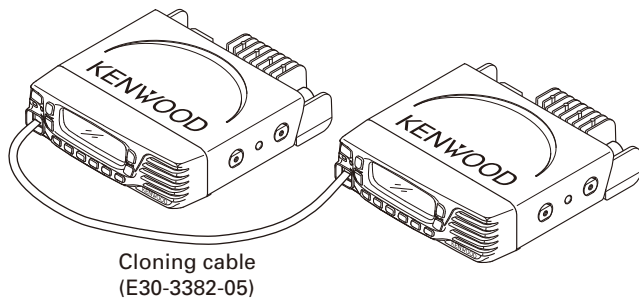
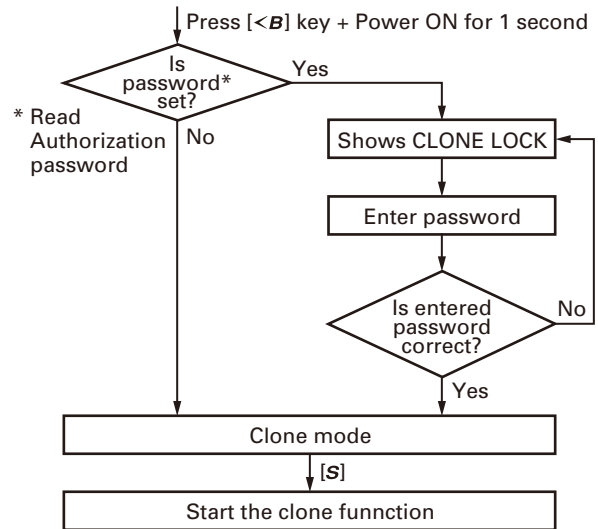

Fig. 2

### 6-2. Flow chart (Source transceiver)



## 7. Firmware Version Information

Press and hold the [**Δ**] key while turning the transceiver power ON and then keep pressing and holding the [**Δ**] key, the firmware version information appears on the LCD.

## INSTALLATION

### 1. Connection Cable (KCT-60: Option)

The KCT-60 connection cable kit is used to connect the transceiver to a Horn alert cable, KCT-18 (Ignition sense cable), KES-5 (External speaker), or through the KCT-36 extension cable.

#### 1-1. Installing the KCT-60 (Connection cable) in the transceiver

1. Remove the ACC. cap on the rear of the transceiver.
2. Connect the D-sub connector of the KCT-60 to the D-sub 15-pin terminal of the transceiver.
3. Connect the 15-pin connector of the KCT-60 to a Horn alert cable, KCT-18, KES-5, or through a KCT-36 extension cable.

**Note:** You must setup using the KPG-135D(K) or KPG-135D(M).

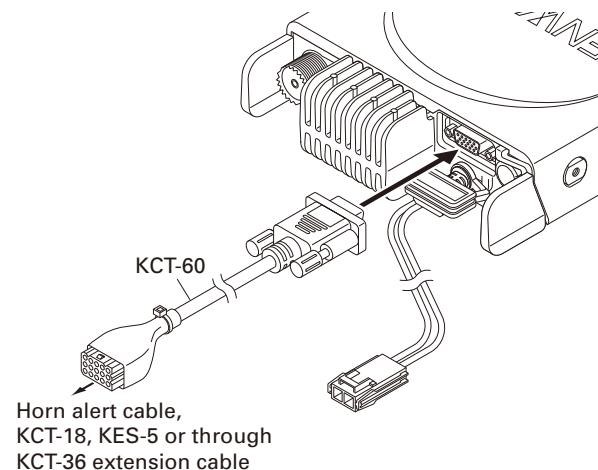

## INSTALLATION

### 1-2. Terminal function

D-sub 15-pin Pin No.	Function	Molex 15-pin Pin No.
1	SB	1
2	IGN	2
3	PA	12
4	DO	4
5	DI	5
6	FNC1	9
7	FNC2	11
8	FNC3	7
9	FNC4	6
10	FNC5	8
11	FNC6	10
12	5C	-
13	HR1	13
14	HR2	14
15	GND	3

## 2. Horn Alert Function

The Horn alert function (max. 2A drive) is enabled by installing the KCT-60 in the transceiver.

### 2-1. Installation Procedure

1. Remove the chip resistor R863 (4.7kΩ) on the TX-RX unit before installing the KCT-60 in the transceiver.

### Combination of Horn alert function and Ignition function

R863	KCT-18	Horn alert function	Ignition function	
Present	Absent	Always inactive	Inactive	Default
Absent	Present	Active when ignition is off	Active	
Absent	Absent	Always active	Transceiver cannot be turned on if the ignition function is set	
Present	Present	Do not use this configuration	Do not use this configuration	

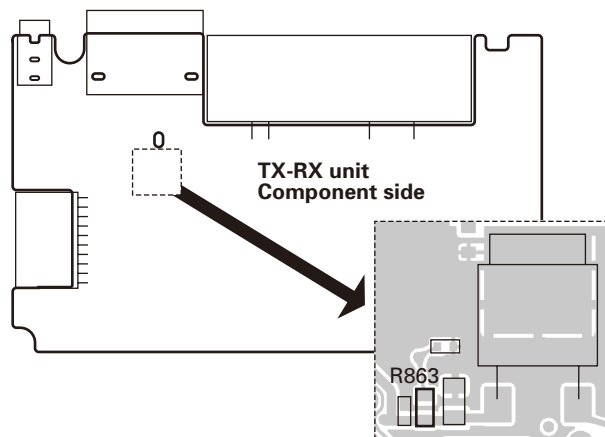

2. Remove the ACC. cap on the rear of the transceiver.
3. Connect the D-sub connector of the KCT-60 to the D-sub 15-pin terminal of the transceiver.
4. Insert the two crimp terminals of the Horn alert cable to pins 13 and 14 of the square plug.
5. Connect the square plug to the 15-pin connector of the KCT-60.
6. Connect the remaining two Horn alert cables to your car Horn alert signal control.

The internal FET switch can be controlled by turning the HA function on/off and by using a signaling decode output. The maximum current of HA is 2A. This FET switch is the open drain circuit. Therefore, a DC power supply is necessary to use the HR1. The voltage range is from 5V to 16V.

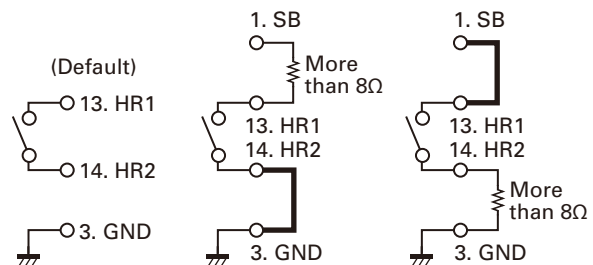

**Note:** You must set up using the KPG-135D(K) or KPG-135D(M).

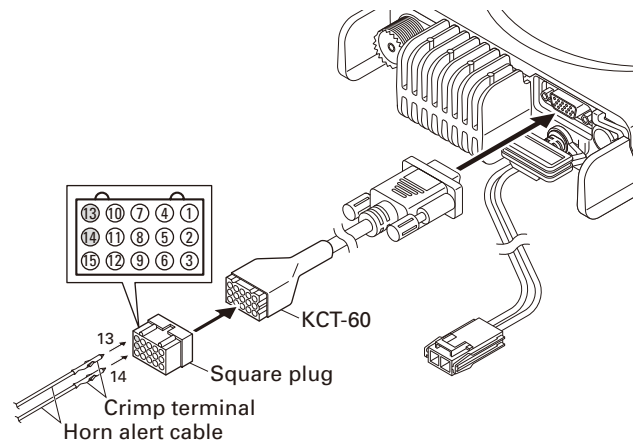

## 3. Ignition Sense Cable (KCT-18: Option)

The KCT-18 is an optional cable for enabling the ignition function. The ignition function lets you turn the transceiver power on and off with the car ignition key.

### 3-1. Installing the KCT-18 (Ignition sense cable) in the transceiver

1. The KCT-18 can be installed in the transceiver by the following two methods (Method A, Method B).  
 Method A: The KCT-18 is soldered to the "IGN" pad on the TX-RX unit.  
 Method B: The KCT-18 is connected to the 15-pin connector of the KCT-60 connected to the transceiver.

## INSTALLATION

### ■ Installation Procedure: Method A

1. Remove the two screws on both the right and left sides of the transceiver, then remove the cabinet and top packing from the transceiver.
2. Remove the chip resistor R863 (4.7kΩ) on the TX-RX unit.

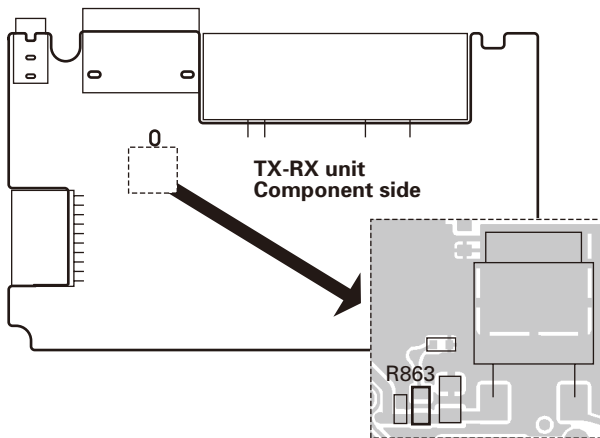

3. Cut the crimp terminal side of the KCT-18 using a pair of nippers or similar tool.

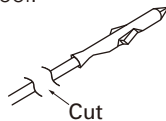

4. Solder the cable side cut in the above step 3 to the "IGN" pad on the TX-RX unit.

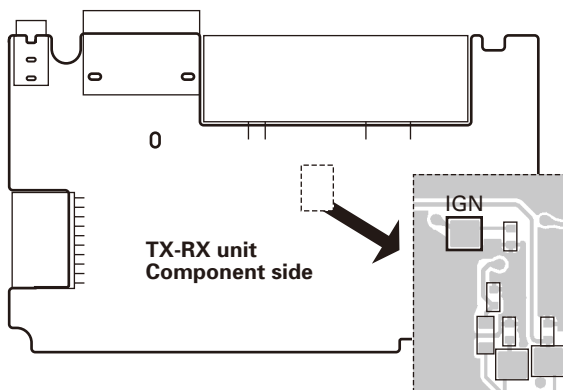

5. Dress the KCT-18 cable as shown in the figure. The KCT-18 cable needs to pass through one of two indentations located on the rear panel of the transceiver.

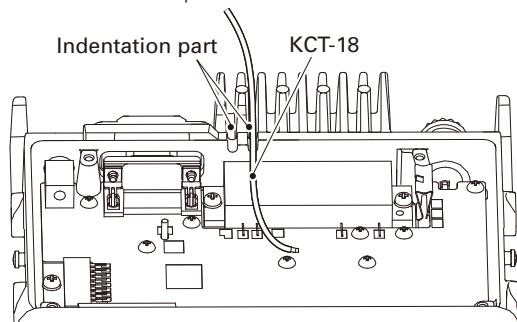

6. Cut off the projection of the top packing using a pair of nippers or similar tool.

If the KCT-18 cable is dressed to be routed through the indentations on the right side in step 5, the right side of the projection needs to be cut off. If the KCT-18 cable is dressed to be routed through the indentations on the left side, the left side of the projection needs to be cut off. Following is a figure presenting an example for when the right side of the projection is cut off.



7. Reinstall the top packing. Check the correct fitting of the top packing, then reinstall the cabinet and two screws for the right and left sides.
8. Connect the other side of the KCT-18 to the ignition line of the car.

### ■ Installation Procedure: Method B

1. Remove the two screws on both the right and left sides of the transceiver, then remove the cabinet and top packing from the transceiver.
2. Remove the chip resistor R863 (4.7kΩ) on the TX-RX unit.

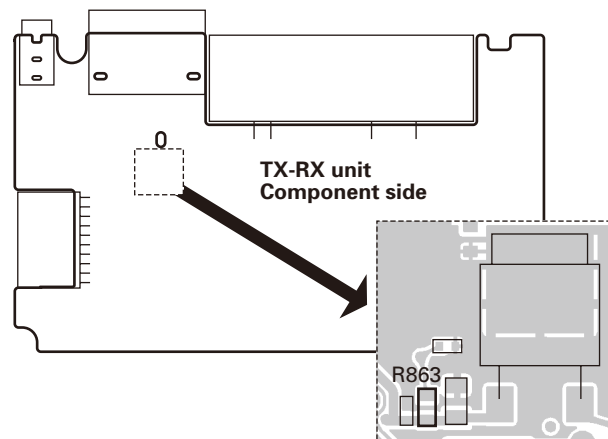

3. Remove the ACC. cap on the rear of the transceiver.
4. Connect the D-sub connector of the KCT-60 to the D-sub 15-pin terminal of the transceiver.
5. Insert the crimp terminal side of the KCT-18 to pin 2 of the square plug.
6. Connect the square plug to the 15-pin connector of the KCT-60.
7. Connect the other side of the KCT-18 to the ignition line of the car.

**Note:** You must set up using the KPG-135D(K) or KPG-135D(M).



## INSTALLATION

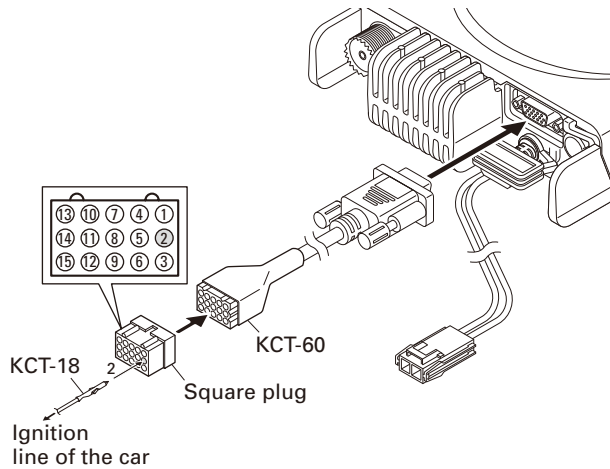

### 4. External Speaker (Option)

#### 4-1. KES-3

The KES-3 is an external speaker for the 3.5-mm-diameter speaker jack.

#### ■ Connection procedure

1. Remove the speaker-jack cap on the rear of the transceiver.
2. Connect the KES-3 to the 3.5-mm-diameter speaker jack on the rear of the transceiver.

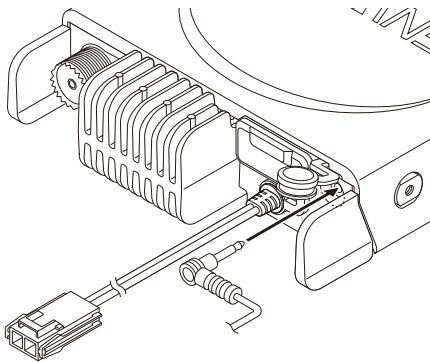

#### 4-2. KES-5

External speaker KES-5 can be installed for KCT-60.

#### ■ Connection procedure

1. Remove the ACC. cap on the rear of the transceiver.
2. Connect the D-sub connector of the KCT-60 to the D-sub 15-pin terminal of the transceiver.
3. Insert the two crimp terminals of the KES-5 to pins 3 and 12 of the square plug.
4. Connect the square plug to the 15-pin connector of the KCT-60.

#### Note:

You must set up using the KPG-135D(K) or KPG-135D(M). Before the external speaker can be used, you must assign one of the keys as "External Speaker", using the KPG-135D(K) or KPG-135D(M).

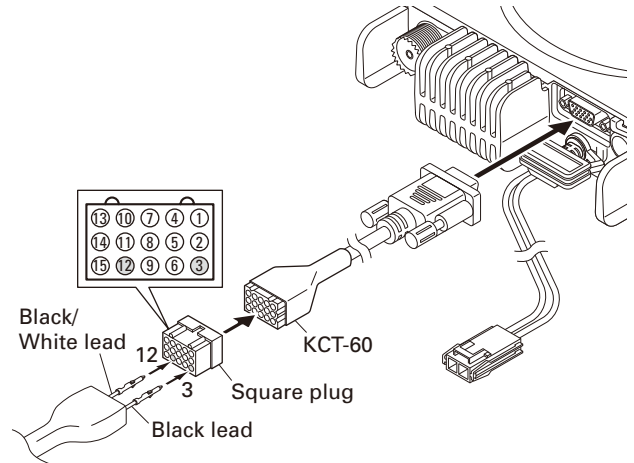

### 5. Voice Guide & Storage Unit (VGS-1: Option)

#### 5-1. Installing the VGS-1 unit in the transceiver

1. Remove the two screws on both sides of the transceiver, then remove the cabinet and top packing from the transceiver.
2. Remove the cover fitted into the TX-RX unit connector (CN700).
3. Attach two cushions to VGS-1
4. Insert the VGS-1 connector (CN1) into the TX-RX unit connector (CN700).

**Note:** You must set up using the KPG-135D(K) or KPG-135D(M).

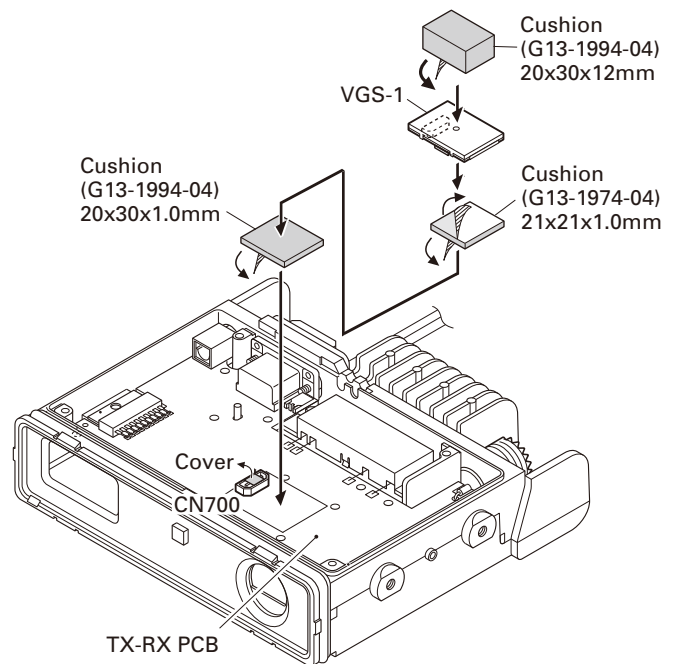

## INSTALLATION

### 6. GPS Receiver Connection

#### 6-1. Installing the GPS receiver

1. Solder each cable of the connector cables to the TX-RX unit.

- Red cable

The red cable needs to be connected to the solder pad (5M) on the TX-RX unit.

- Yellow cable

The yellow cable needs to be connected to the solder pad GPS (RS-232C-RXD) on the TX-RX unit.

- Black cable

The black cable needs to be connected to the solder pad (GND) on the TX-RX unit.

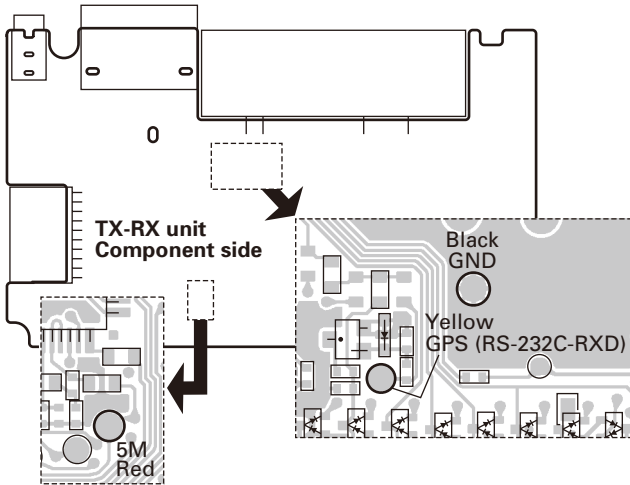

**Note:** You must set up using the KPG-135D(K) or KPG-135D(M).

### 7. Extended Function: COM Port 0 and COM Port 1

Location of COM Port 0 and COM Port 1 of the transceiver is shown below.

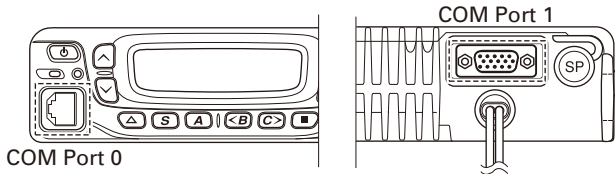

You must configure the transceiver COM Port 0 and COM Port 1 using the KPG-135D(K) or KPG-135D(M).

When you set as "Data", the Function port 1 and 2 will be automatically fixed as Input ports. The reason for this is because function port 1 (TXD) and 2 (RXD) share the same circuit path of TXD and RXD line.

### 8. Changing Serial Port Level

#### 8-1. Change FNC2 (RXD) of D-SUB 15-pin connector from TTL level to RS-232C level

FNC2 (RXD) of D-SUB 15-pin connector is configured at the TTL level as the default value. But you can change this serial port level to RS-232C level by configuring the port.

Remove the R726 chip jumper and solder the clip jumper to R727.

#### 8-2. Change FNC1 (TXD) and FNC2 (RXD) of D-SUB 15-pin connector from TTL level to RS-232C level

FNC1 (TXD) and FNC2 (RXD) of D-SUB 15-pin connector are configured at the TTL level as the default value. But you can change these serial port level to RS-232C level through the RS-232C level converter IC (IC700) by configuring the port.

Remove the R760 and R761 chip jumpers and solder the chip jumpers to R752, R753, R767 and R768.

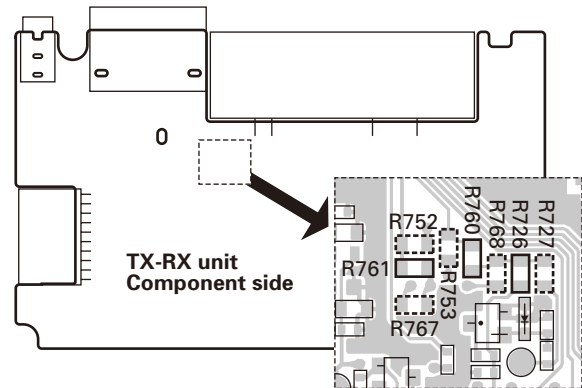

#### ■ In the case of 8-1.

##### [TTL level]

R726, R760 and R761: 0Ω chip jumper.  
R727, R752, R753, R767 and R768: open.

##### [RS-232C level]

R727, R760 and R761: 0Ω chip jumper.  
R726, R752, R753, R767 and R768: open.

#### ■ In the case of 8-2.

##### [TTL level]

R726, R760 and R761: 0Ω chip jumper.  
R727, R752, R753, R767 and R768: open.

##### [RS-232C level]

R726, R752, R753, R767 and R768: 0Ω chip jumper.  
R727, R760 and R761: Open.

## DISASSEMBLY FOR REPAIR

### 1. Disassembly Procedure

1. When removing the cabinet, first remove the two screws from the right and left with a phillips screwdriver. Then, hook your finger on the edge of the cabinet and pull it out until it is over the chassis protrusion. Remove the cabinet by prying the cabinet as shown below.

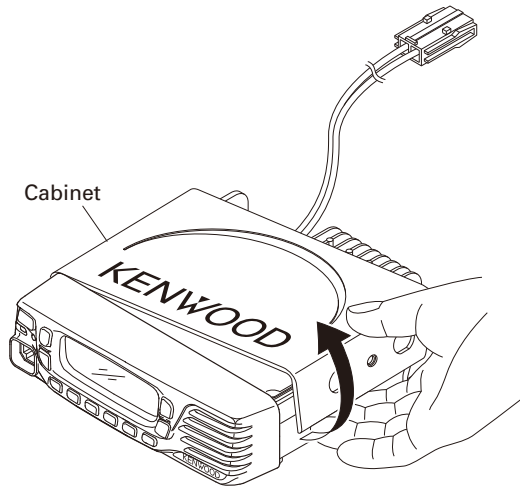

2. To remove the panel assembly, first turn the transceiver upside down. Then, insert a flat-head screwdriver into the holes of the chassis and tilt it in the direction as shown by the arrow.

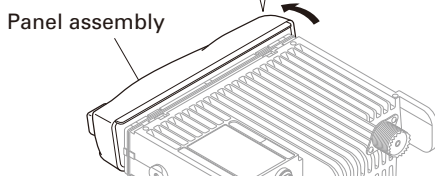
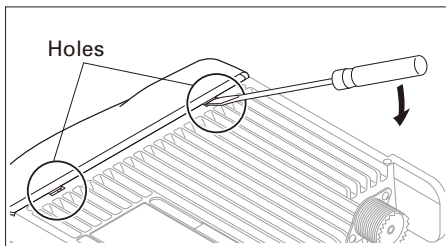

3. Disconnect the flat cable from connector of the panel assembly.

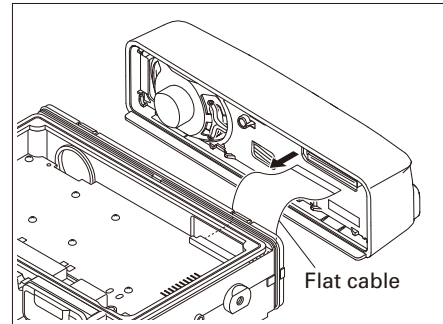

4. Hook the finger to hole and while pulling the speaker holder to this side, expand the panel side of ① to ③, and remove the speaker holder from the front panel.

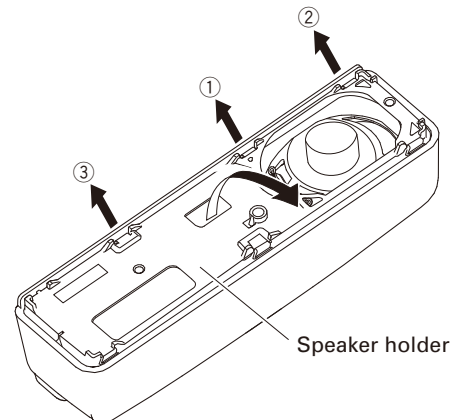

5. When removing the TX-RX PCB, first remove the top packing. Then, remove the solder of the antenna hot pin and positive terminal of the DC cord. Remove the 15 screws from the TX-RX PCB, power module, and audio amp.

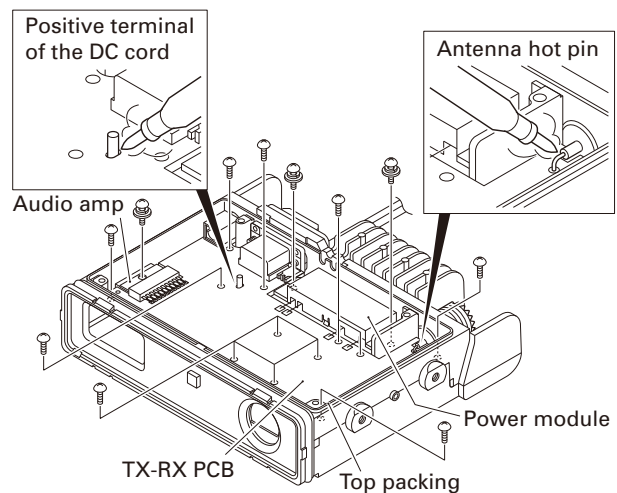

## DISASSEMBLY FOR REPAIR

### Note:

When you supply power to the TX-RX PCB after removing the TX-RX PCB from the chassis, solder the positive and ground terminals of the DC cord (Recommendation: E30-3448-25) to the + and GND terminals of the TX-RX PCB.

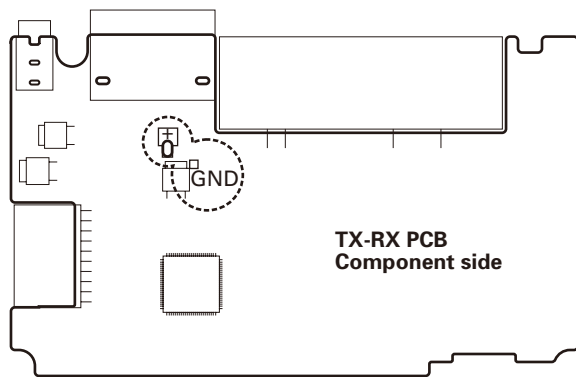

- Pull it out behind the chassis by rotating the bush ③ of the DC cord 90 degrees in the direction of the arrow after the screw ① in the negative terminal is removed, and the positive terminal ② is removed from the chassis.

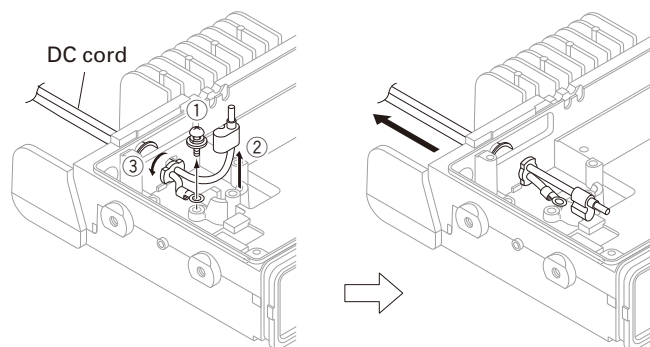

### 2. Precautions for Reassembly

- The tab from ① to ③ is applied the front panel first. And, ④ to ⑥ tabs inside the front panel is pushed.

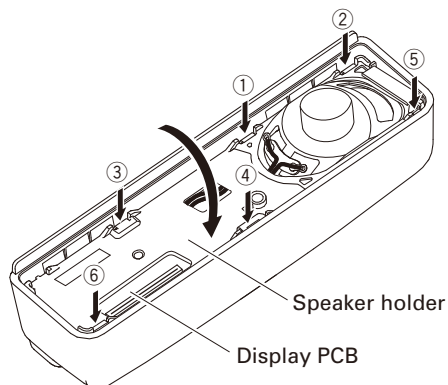

- When mounting the panel assembly, pass the flat cable through the hole of the chassis as shown below then connect the flat cable to connector of the panel assembly.

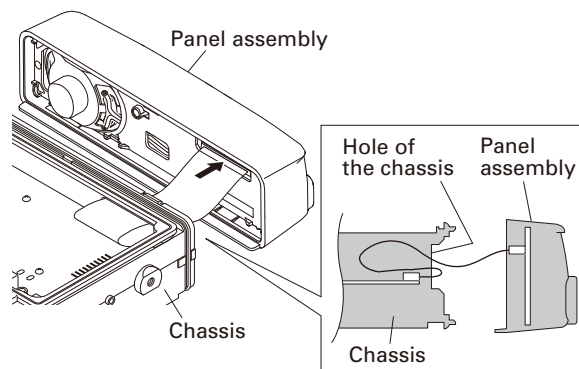

- Fit the panel assembly into the two tabs of the chassis top side first. Then, fit the panel assembly into the two tabs of the chassis bottom side by turning the panel assembly.

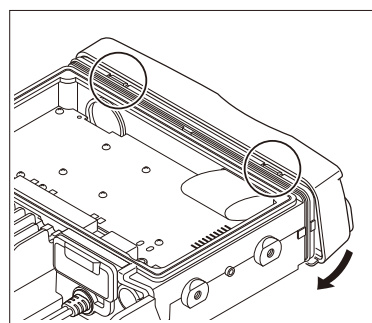

### 3. Correspondence when replacing the LED (D22 and D23)

When replacing the LED (D22 and D23), it makes it to length.

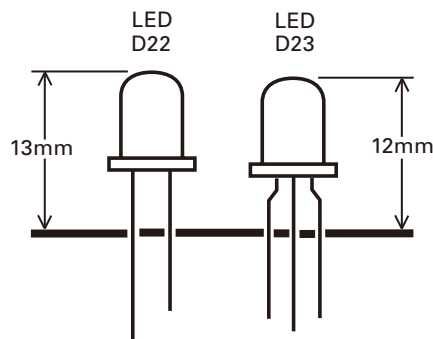

## CIRCUIT DESCRIPTION

### 1. Frequency Configuration

The receiver utilizes double conversion. The first IF is 38.85MHz and the second IF is 450kHz. The first local oscillator signal is supplied from the PLL circuit.

The PLL circuit in the transmitter generates the necessary frequencies. Figure 1 shows the frequencies.

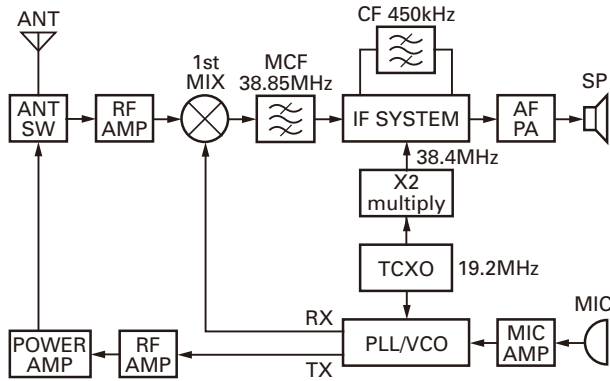

Fig. 1 Frequency configuration

### 2. Receiver System

The receiver is a double conversion superheterodyne. The frequency configuration is shown in Figure 1.

#### 2-1. Front-end RF Amplifier

An incoming signal from the antenna is applied to an RF amplifier (Q511) after passing through the transmit/receive switch circuit (D303, D304, D307, D308 and D311), BPF (L518, L519 and varactor diodes: D506, D507) and the Notch filter (L523 and varactor diode: D508). The Notch filter function is to eliminate the image frequency.

After the signal is amplified (Q511), the signal is filtered by the bandpass (L512, L513, L514 and varactor diodes: D503, D504, D505) to eliminate unwanted signals before it is passed to the first mixer.

The voltage of these diodes are controlled by tracking the MCU (IC704) center frequency of the bandpass filter. (See Figure 2)

#### 2-2. First Mixer

The signal from the RF amplifier is heterodyned with the first local oscillator signal from the PLL frequency synthesizer circuit at the first mixer (Q507) to create a 38.85MHz first intermediate frequency (1st IF) signal. The first IF signal is then fed through one pair of monolithic crystal filters (MCF: XF500) to further remove spurious signals.

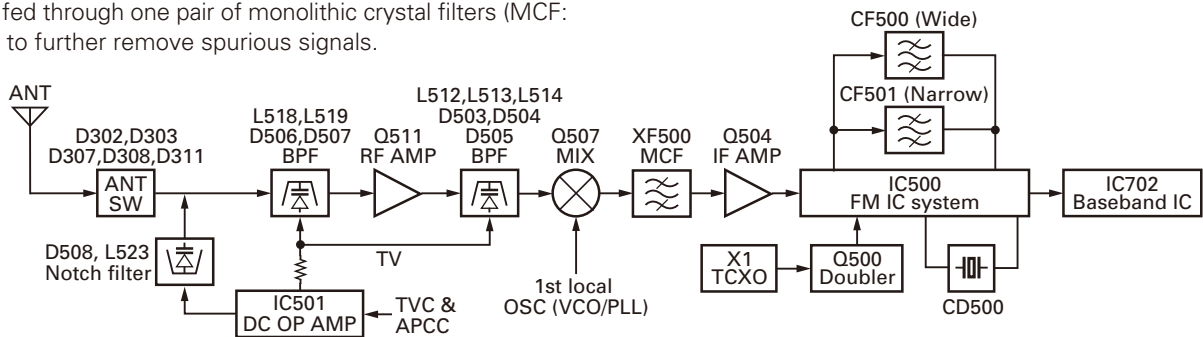

Fig. 2 Receiver System

Item	Rating
Nominal center frequency	38.85MHz
Pass bandwidth	±6.0kHz or more at 3dB
40dB stop bandwidth	±25.0kHz or less
Ripple	1.0dB or less
Insertion loss	4.0dB or less
Guaranteed attenuation	75dB (-900kHz); 50dB (+900kHz) Spurious: 40dB or more within fo±1MHz
Terminal impedance	610Ω// 3.0pF// Coupling Cap 13.0pF

Table 1 Crystal filter (L71-0659-05): XF500

#### 2-3. IF Amplifier Circuit

The first IF signal is amplified by Q504, and enters IC500 (FM processing IC). The signal is heterodyned again with a second local oscillator signal within IC500 to create a 450kHz second IF signal. The second IF signal is then fed through a 450kHz ceramic filter (Wide: CF500, Narrow: CF501) to further eliminate unwanted signals before it is amplified and demodulated by the quadrature detector with the ceramic discriminator (CD500).

Item	Rating
Nominal center frequency	450kHz
6dB bandwidth	±6.0kHz or more
50dB bandwidth	±12.5kHz or less
Ripple	2.0dB or less
Insertion loss	6.0dB or less
Guaranteed attenuation	35.0dB or more within fo±100kHz
Terminal impedance	2.0kΩ

Table 2 Ceramic filter (L72-0993-05): CF500

Item	Rating
Nominal center frequency	450kHz
6dB bandwidth	±4.5kHz or more
50dB bandwidth	±10.0kHz or less
Ripple	2.0dB or less
Insertion loss	6.0dB or less
Guaranteed attenuation	60.0dB or more within fo±100kHz
Terminal impedance	2.0kΩ

Table 3 Ceramic filter (L72-0999-05): CF501

## CIRCUIT DESCRIPTION

### 2-4. Wide/Narrow Switching Circuit

The Wide port (pin 99) and Narrow port (pin 98) of the MCU is used to switch between ceramic filters. When the Wide port is high, the ceramic filter switch diodes (D500, D501) cause CF500 to turn on to receive a Wide signal.

When the Narrow port is high, the ceramic filter switch diodes (D500, D501) cause CF501 to turn on to receive a Narrow signal.

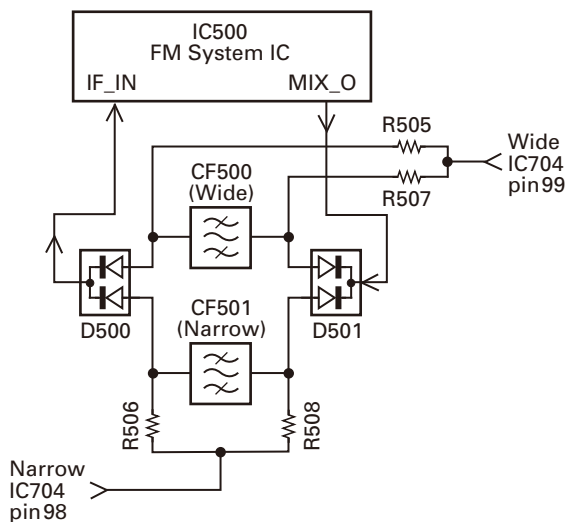
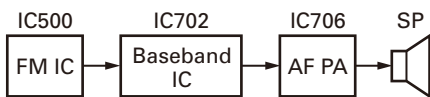

**Fig. 3 Wide/Narrow switching circuit**

### 2-5. AF Signal System

The detection signal from the FM IC (IC500) goes to the baseband IC (IC702) DISC input (pin 16) for characterizing the signal.

The AF signal output from IC702 is input to the audio power amplifier (IC706). The AF signal from IC706 switches between the internal speaker and the speaker jack (J701) output.



**Fig. 4 AF signal system**

### 2-6. Squelch Circuit

The detection output from the FM IC (IC500), a voltage is applied to the MCU (IC704). The MCU controls squelch according to the voltage (SQIN) level.

The signal from the RSSI pin of IC500 is monitored.

The electric field strength of the receive signal can be known before the SQIN voltage is input to the MCU, and the scan stop speed is improved.

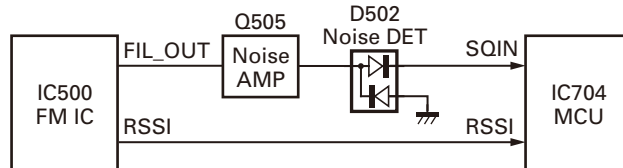

**Fig. 5 Squelch circuit**

## 3. Transmitter System

### 3-1. Outline

The transmitter circuit produces and amplifies the desired frequency directly. It FM-modulates the carrier signal by means of a varicap diode.

### 3-2. Power Amplifier Circuit

The transmit output signal from the VCO passes through the transmission/reception selection diode (D17) and amplified by Q300. The amplified signal goes to the RF power module (IC300) through a low-pass filter. The lowpass filter removes unwanted high-frequency harmonic components, and the resulting signal goes through the antenna terminal.

### 3-3. APC Circuit

The automatic transmission power control (APC) circuit detects part of a final amplifier output with a coupler circuit and applies a voltage to IC301. IC301 compares the APC control voltage (PC) generated by the baseband IC (IC702) and DC amplifier (IC501) with the detection output voltage. IC301 generates the voltage to control IC300 and stabilizes transmission output.

The APC circuit is configured to protect over current of Q300 and IC300 due to fluctuations of the load at the antenna end and to stabilize transmission output at voltage and temperature variations.

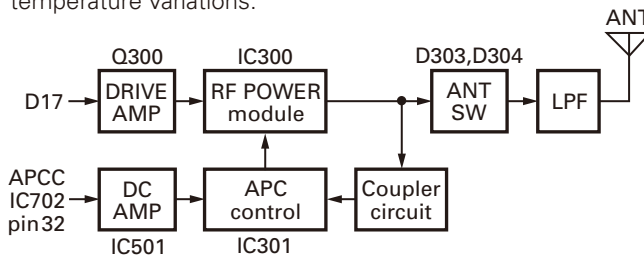

**Fig. 7 APC circuit**

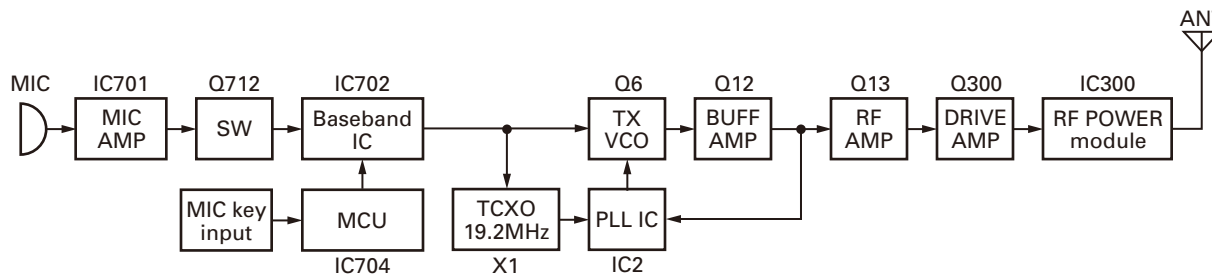

**Fig. 6 Transmitter system**

## CIRCUIT DESCRIPTION

### 4. PLL Frequency Synthesizer

The PLL circuit generates the first local oscillator signal for reception and the RF signal for transmission.

#### 4-1. PLL Circuit

The frequency step of the PLL circuit is 5, 6.25, 10 or 12.5kHz.

A 19.2MHz reference oscillator signal is divided at IC2 by a fixed counter to produce the 5, 6.25, 10 or 12.5kHz reference frequency. The voltage controlled oscillator (VCO) output signal is buffer amplified by Q12, then divided by a programmable counter in IC2.

The divided signal is compared in phase with the 5, 6.25, 10 or 12.5kHz reference signal in the phase comparator in IC2. The output signal from the phase comparator is filtered

through a low-pass filter and passed to the VCO to control the oscillator frequency.

#### 4-2. VCO Circuit

The operating frequency is generated by Q6 in transmit mode and Q8 in receive mode. The oscillator frequency is controlled by applying the VCO control voltage, obtained from the phase comparator to the varactor diodes (D7 in transmit mode and D9 in receive mode) and assist voltage to the (D10, D12 and D13 in transmit mode and D11, D14 and D15 in receive mode).

The TX/RX pin is set high in receive mode causing Q7 to turn off, and turn Q10 on. The TX/RX pin is set low in transmit mode. The outputs from Q8 and Q6 are amplified by Q12 and sent to the RF amplifiers.

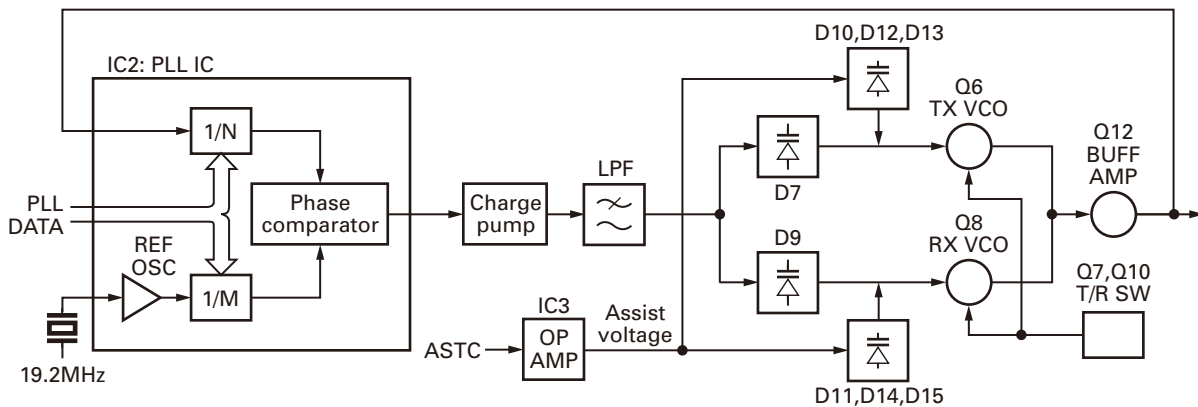

Fig. 8 PLL circuit

#### 4-3. Unlock Circuit

During reception, the 9RC signal goes high, the 9TC signal goes low, and Q400 turns on. Q402 turns on and a voltage is applied to the collector (9R). During transmission, the 9RC signal goes low, the 9TC signal goes high and Q401 turns on. Q403 turns on and a voltage is applied to 9T.

The MCU in the control unit monitors the PLL (IC2) LD signal directly. When the PLL is unlocked during transmission, the PLL LD signal goes low. The MCU detects this signal and makes the 9TC signal low. When the 9TC signal goes low, no voltage is applied to 9T, and no signal is transmitted.

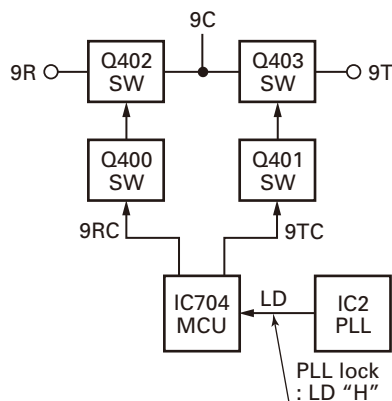

Fig. 9 Unlock circuit

### 5. Control Circuit

The MCU carries out the following tasks:

- 1) Controls the WIDE, NARROW, TX/RX outputs.
- 2) Controls the Baseband IC (IC702).
- 3) Controls the PLL (IC2).
- 4) Controls the display unit.

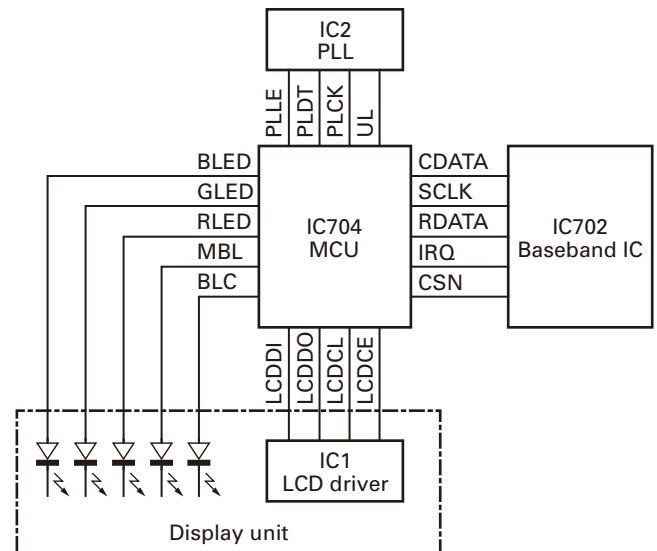

Fig. 10 Control circuit

## CIRCUIT DESCRIPTION

### 5-1. Memory Circuit

The transceiver has a 512k-bit EEPROM (IC705). The EEPROM contains adjustment data. The MCU (IC704) controls the EEPROM through three serial data lines.

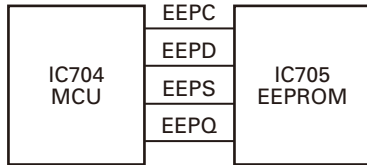

Fig. 11 Memory circuit

### 5-2. Display Circuit

The MCU (IC704) controls the LCD display and LEDs.

When power is on, the MCU will use the MBL line and the BLC line to control the key backlight LEDs and LCD backlight LEDs.

When the transceiver is busy, the GLED line goes high, Q6 turns on and the green LED (D23) lights after Q5 turns on. In transmit mode, the RLED line goes high, Q3 and Q4 turn on and the red LED (D23) lights.

BLED will be set high when the function select (FPU setting) is on, Q2 turns on and the blue LED (D22) lights.

The LCD driver (IC1) controls the functions of the LCD through the LCDDI, LCDDO, LCDCL, LCDCE lines from the MCU.

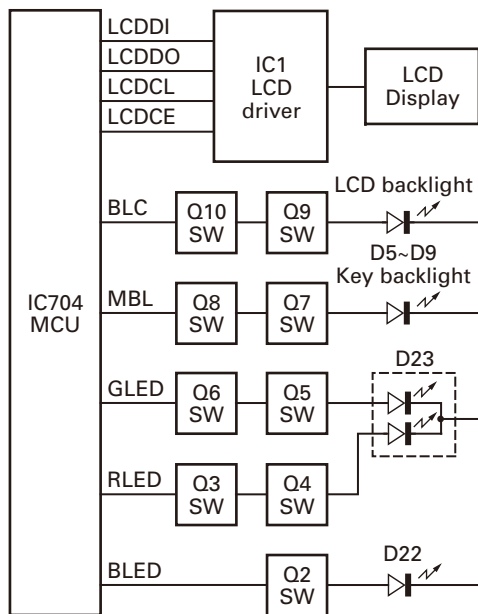

Fig. 12 Display circuit

### 5-3. Key Matrix Circuit

The front panel has function keys. Each of them is connected to a cross point of a matrix of the KMI1 to KMO3 ports of the LCD driver. The KMO1 to KMO3 ports are always high, while the KMI1 to KMI3 ports are always low.

The LCD driver monitors the status of the KMI1 to KMO3 ports. If the state of one of the ports changes, the LCD driver assumes that the key at the matrix point corresponding to that port has been pressed.

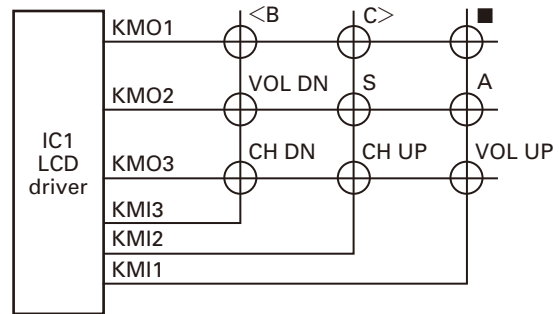

Fig. 13 Key matrix circuit

## 6. Signaling Circuit

### 6-1. Encode

#### ■ Low-speed data (QT, DQT)

Low-speed data is output from pin 26 (LSDO) of the MCU (IC704). The signal passes through a low-pass CR filter. The signal is mixed with the audio signal and goes to the VCO and TCXO (X1) modulation input after signal processing in the baseband IC (IC702).

#### ■ High-speed data (2-tone)

High-speed data (HSD) is output from pin 2 (HSDO) of the MCU.

The signal passes through a low-pass CR filter. TX deviation making an adjustment by MCU is applied to the baseband IC (IC702). The signal is mixed with the audio signal and goes to the VCO and TCXO.

The RX tone is audio output of the baseband IC (IC702) at the same time to audio power amplifier and then to the speaker.

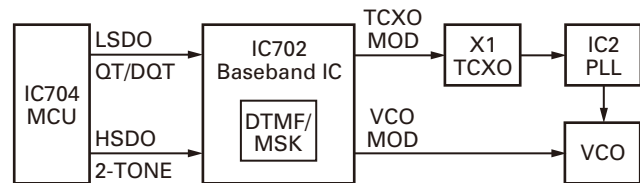

Fig. 14 Encode

#### ■ MSK / DTMF

MSK and DTMF signal is self generated by the baseband IC (IC702).

The TX deviation adjustment is done by the output gain of the baseband IC (IC702), and is routed to the VCO. When encoding MSK/DTMF, the microphone-input signal is muted.

### 6-2. Decode

#### ■ Low-speed data (QT, DQT)

The demodulated signal from the FM IC (IC500) will input to the baseband IC (IC702) to remove frequencies of 300Hz or more.

The signal is input to pin 88 (LSDI) of the MCU. The MCU digitizes this signal, performs processing such as DC restoration, and decodes the signal.



## CIRCUIT DESCRIPTION

### High-speed data (2-tone)

The demodulated signal from the FM IC (IC500) is amplified by the baseband IC and passes through a band pass filter and a comparator (IC709) to detect the signal to the MCU. The MCU digitizes this signal and decodes the signal after receiving the signal at pin 5 (HSDI).

### MSK/ DTMF

The demodulated signal from the FM IC (IC500) will input to the baseband IC (IC702), then the baseband IC will decode and send the decoded information to the MCU by the data line.

The MCU then processes the decoded information.

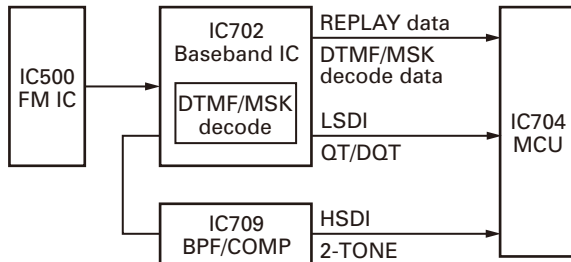

Fig. 15 Decode

### 7. Power Supply Circuit

When the power switch on the display unit is pressed, the power port on the display unit which is connected to port 17 (POWER), goes low, then port 52 (SBC) goes high, Q406 turns on, SB switch (Q407) turns on and power (SB) is supplied to the transceiver.

When the DC power is supplied to the transceiver, voltage regulator IC (IC401, IC402) will supply into the MCU VDD and reset the voltage detect IC (IC404). IC404 will generate signal (RESET) into the reset terminal on the MCU (IC704) to carry out a power on reset. Also, MCU (IC704) is checking on port 91 (BATT). If DC power is less than about 8.5V, the transceiver is unable to power on.

When the DC power voltage decreases from normal voltage, the INT voltage detector IC (IC403) will set to high on MCU port 18 (INT). If B line becomes less than about 8.5V, MCU will send the backup data to EEPROM (IC705) and go into STOP mode.

This circuit has an overvoltage protection circuit. If a DC voltage of 16V or higher is applied to the base of Q717, this voltage turns Q717 on and sets port 18 (INT) to low. As a result port 78 (SBC) is low, and turns Q406 and Q407 (SB) off.

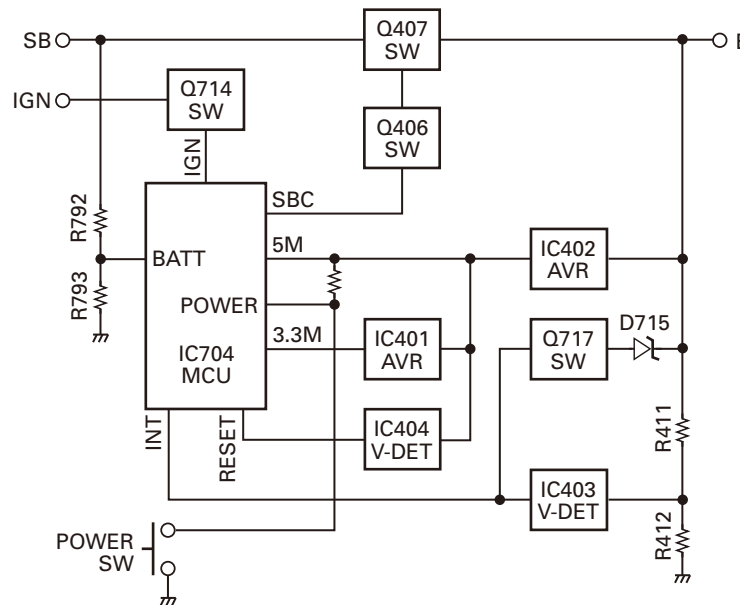

Fig. 16 Power supply circuit

## SEMICONDUCTOR DATA

## MCU: F3650TDFBKEBA (TX-RX unit IC704)

Pin No.	Name	I/O	Function
1	FREQ	O	Frequency alignment
2	HSDO	O	High speed data output
3	LCDDO	O	LCD data output
4	LCDCE	O	LCD enable
5	HSDI	I	High speed data input
6	E	-	GND (Only for bus control)
7	CNVSS	I	CNVSS for emulator (H: boot mode)
8	LCDDI	I	LCD data input
9	LCDCL	O	LCD clock output
10	RESET	I	Reset
11	XOUT	O	11.0592MHz clock output
12	VSS	-	GND
13	XIN	I	11.0592MHz clock input
14	VCC1	-	+5V
15	5CC	O	5C control
16	MKEY	I/O	Mic key detect
17	POWKEY	I	Power key detect
18	INT	I	MCU stop
19	ASTSW	O	Assist speed up switch control
20	BEEP	O	Beep for side tone
21	FNC8	I/O	Function port 8
22	FNC7	I/O	Function port 7 (REC/SRC)
23	FNC6	I/O	Function port 6
24	FNC5	I/O	Function port 5
25	FNC4	I/O	Function port 4
26	LSDO	O	Low speed data output
27	SI	I	Serial data input for VGS
28	SO	O	Serial data output for VGS
29	FNC1	I/O	Function port 1 (TXD to COM port 1)
30	FNC2	I/O	Function port 2 (RXD from COM port 1)
31	ECLK	-	SCLK for emulator
32	FNC3/EBSY	I/O	Function port 3 / BUSY for emulator
33	TXD	I/O	TXD to FPU
34	RXD	I/O	RXD from FPU
35	HOOK	I	Hook
36	PTT	I	PTT
37	BSFT	O	Beat shift (L: beat shift ON)
38	LPOSW	O	No use
39	EPM	-	EPM for emulator
40	PLLE	O	PLL lock enable
41	PLDT	O	PLL data output
42	PLCK	O	PLL clock output

Pin No.	Name	I/O	Function
43	PA	O	Public address control
44	CE	-	CE for emulator
45	CDATA	O	Command data output for baseband IC
46	RDATA	I	Reply data input for baseband IC
47	SCLK	O	Serial clock output for baseband IC
48	CSN1	O	Chip select for baseband IC
49	SP MUTE	O	Speaker mute control
50	9RC	O	9R control
51	9TC	O	9T control
52	SBC	O	SB control
53	3CC	O	3C control
54	PLPS	O	Sleep mode function for PLL IC
55	EEPS	O	EEPROM chip select
56	AMPSW	O	AF AMP switch control (L: enable / H: disable)
57	EEPQ	I	EEPROM serial data input
58	EEPD	O	EEPROM serial data output
59	EEPC	O	EEPROM serial clock output
60	VCC2	-	+3.3V
61	SCRSW	O	Scrambler switch control (Audio path)
62	VSS	-	GND
63	NC	-	No connection
64	TXRX	O	TX/RX (H: RX / L: TX)
65	BLC	O	LCD backlight control
66	MBL	O	Panel and mic key backlight control
67	NC	-	No connection
68	DST	I	Destination
69	NC	-	No connection
70	NC	-	No connection
71	STSW	O	Side tone switch control for VGS playback
72	IGN	I	Ignition
73	IRQ1	I	Interrupt request for baseband IC
74	RLED	O	Red LED for TX
75	GLED	O	Green LED for busy
76	BLED	O	Blue LED for VGS writing and signaling
77	VGSRX	O	VGS recording switch control for RX
78	NC	-	No connection
79	NC	-	No connection
80	EMG	I	Emergency key detect
81	NC	-	No connection
82	NC	-	No connection
83	UL	I	PLL unlock detect
84	DMUTE	O	Det mute control

## SEMICONDUCTOR DATA

Pin No.	Name	I/O	Function
85	MIC1MUTE	O	Internal mic mute control
86	MIC2MUTE	O	External mic mute control
87	HSDI	I	No use
88	LSDI	I	Low speed data input: QT/DQT/(LTR)
89	TEMP2	I	Temperature 2 data input
90	TEMP1	I	Temperature 1 data input
91	BATT	I	Battery voltage input
92	RSSI	I	RSSI input

Pin No.	Name	I/O	Function
93	SQIN	I	Squelch input
94	AVSS	-	GND
95	CV	I	VCO lock voltage detect
96	VREF	-	+5V
97	AVCC	-	+5V
98	NARROW	O	Wide/Narrow control (Hi: Narrow)
99	WIDE	O	Wide/Narrow control (Hi: Wide)
100	HORN	O	Horn alert switch control

## COMPONENTS DESCRIPTION

### Display unit (X54-3740-20)

Ref. No.	Part Name	Description
IC1	IC	LCD driver
Q2	Transistor	Indication LED (BLUE) switch
Q3	Transistor	TX LED switch control
Q4	Transistor	TX LED switch
Q5	Transistor	BUSY LED switch
Q6	Transistor	BUSY LED switch control
Q7	Transistor	KEY backlight switch
Q8	Transistor	KEY backlight switch control
Q9	Transistor	LCD backlight switch control
Q10	Transistor	LCD backlight switch
D1	Zener diode	Surge protection
D2	Diode	Voltage protection
D5~9	LED	KEY backlight
D10	Diode	Voltage protection
D11~21	LED	LCD backlight
D22	LED	Indication (BLUE)
D23	LED	TX/BUSY indication
D24	LED	LCD backlight

### TX-RX unit (X57-8020-XX)

Ref. No.	Part Name	Description
IC1	IC	DC AMP (frequency)
IC2	IC	PLL IC
IC3	IC	Assist filter
IC300	IC	Power module
IC301	IC	DC AMP (APC)
IC400	IC	Voltage regulator (9V)
IC401	IC	Voltage regulator (3.3V)
IC402	IC	Voltage regulator (5V)
IC403	IC	Voltage detection (INT)
IC404	IC	Voltage detection (reset)
IC500	IC	FM SYSTEM IC
IC501	IC	RX BPF/ APC DC AMP
IC700	IC	RS-232C driver
IC701	IC	MIC MOD AMP
IC702	IC	Baseband IC
IC703	IC	Voltage regulator (3.3V)
IC704	IC	MCU
IC705	IC	EEPROM

## COMPONENTS DESCRIPTION

Ref. No.	Part Name	Description
IC706	IC	AF power AMP
IC707,708	IC	Option setting switch
IC709	IC	HSD BPF/COMP
IC710	IC	MOD/ Option setting switch
Q1	Transistor	Buffer AMP (PLL IC clock)
Q4	FET	Assist filter switch
Q5	FET	Assist filter switch control
Q6	FET	TX VCO
Q7	Transistor	TX/RX VCO switch
Q8	FET	RX VCO
Q10	Transistor	T/R VCO switch
Q11	Transistor	Ripple filter
Q12	Transistor	Buffer AMP
Q13	Transistor	RF AMP
Q300	Transistor	TX drive AMP
Q400	Transistor	9R switch control
Q401	Transistor	9T switch control
Q402	Transistor	9R switch
Q403	Transistor	9T switch
Q404	FET	5C switch
Q405	FET	3.3C switch
Q406	Transistor	SB switch
Q407	FET	SB switch control
Q500	Transistor	Doubler (2nd local)
Q502	Transistor	W/N switch
Q503	Transistor	W/N switch control
Q504	Transistor	IF AMP
Q505	Transistor	Squelch noise AMP
Q506	Transistor	Squelch input switch
Q507	FET	1st mixer
Q508	Transistor	Squelch input switch
Q511	FET	RF AMP
Q700	Transistor	RS-322C RXD buffer
Q702	FET	Horn alert switch
Q703	Transistor	MIC mute switch
Q704	FET	MIC mute switch
Q705	Transistor	Horn alert switch control
Q708	Transistor	DET AMP (D-SUB)
Q709	FET	TX/RX switch

Ref. No.	Part Name	Description
Q710	Transistor	Baseband IC clock AMP
Q712	FET	Option switch
Q713	FET	DET mute switch
Q714	Transistor	IGN switch
Q715	Transistor	Beet shift switch
Q716,717	Transistor	Over voltage detect switch
Q718,719	FET	SP mute
Q720	Transistor	AF AMP switch
D1	Diode	PLL unlock detect
D7	Variable capacitance diode	TX VCO frequency
D9	Variable capacitance diode	RX VCO frequency
D10	Variable capacitance diode	RX VCO assist
D11	Variable capacitance diode	TX VCO assist
D12,13	Variable capacitance diode	RX VCO assist
D14,15	Variable capacitance diode	TX VCO assist
D16	Variable capacitance diode	Modulation
D17,18	Diode	TX/RX RF switch
D300	Zener diode	Voltage protection
D301	Diode	TX power control
D302	Diode	Reverse power detection
D303,304	Diode	ANT switch
D305,306	Diode	RF power detection
D307,308	Diode	ANT switch
D309,310	Zener diode	Voltage protection
D311	Diode	ANT switch
D400	Surge absorber	Voltage protection
D500,501	Diode	W/N CF switch
D502	Diode	Squelch detection
D503~507	Variable capacitance diode	RF BPF tuning
D508	Variable capacitance diode	RX notch tuning
D700~711	Diode	Surge protection
D712,713	Diode	MIC AGC detection
D715	Zener diode	Voltage drop
D716	Diode	Speed up (DET mute)

## PARTS LIST

### CAPACITORS

$\frac{C}{1} \frac{C}{2} \frac{45}{3} \frac{TH}{4} \frac{1H}{5} \frac{220}{6} \frac{J}{6}$

- 1 = Type ... ceramic, electrolytic, etc.
- 2 = Shape ... round, square, etc.
- 3 = Temp. coefficient
- 4 = Voltage rating
- 5 = Value
- 6 = Tolerance

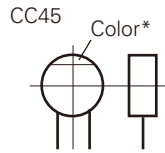

#### • Capacitor value

- 010 = 1pF
- 100 = 10pF
- 101 = 100pF
- 102 = 1000pF = 0.001μF
- 103 = 0.01μF

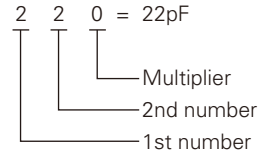

#### • Temperature coefficient

1st Word	C	L	P	R	S	T	U
Color*	Black	Red	Orange	Yellow	Green	Blue	Violet
ppm/°C	0	-80	-150	-220	-330	-470	-750

2nd Word	G	H	J	K	L
ppm/°C	±30	±60	±120	±250	±500

Example : CC45TH = -470±60ppm/°C

#### • Tolerance (More than 10pF)

Code	C	D	G	J	K	M	X	Z	P	No code
(%)	±0.25	±0.5	±2	±5	±10	±20	+40 -20	+80 -20	+100 -0	More than 10μF : -10~+50 Less than 4.7μF : -10~+75

#### (Less than 10pF)

Code	B	C	D	F	G
(pF)	±0.1	±0.25	±0.5	±1	±2

#### • Voltage rating

2nd word	A	B	C	D	E	F	G	H	J	K	V	
1st word	0	1.0	1.25	1.6	2.0	2.5	3.15	4.0	5.0	6.3	8.0	-
1	10	12.5	16	20	25	31.5	40	50	63	80	35	
2	100	125	160	200	250	315	400	500	630	800	-	
3	1000	1250	1600	2000	2500	2150	4000	5000	6300	8000	-	

#### • Chip capacitors

- (EX)  $\frac{C}{1} \frac{C}{2} \frac{73}{3} \frac{F}{4} \frac{SL}{5} \frac{1H}{6} \frac{000}{7} \frac{J}{7}$  Refer to the table above.
- 1 = Type
  - 2 = Shape
  - 3 = Dimension
  - 4 = Temp. coefficient
  - 5 = Voltage rating
  - 6 = Value
  - 7 = Tolerance
- (Chip) (CH, RH, UJ, SL)
- (EX)  $\frac{C}{1} \frac{K}{2} \frac{73}{3} \frac{F}{4} \frac{F}{5} \frac{1H}{6} \frac{000}{7} \frac{Z}{7}$
- (Chip) (B, F)

#### • Dimension

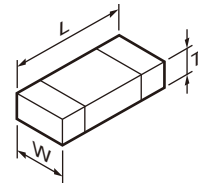

#### Chip capacitor

Code	L	W	T
Empty	5.6±0.5	5.0±0.5	Less than 2.0
A	4.5±0.5	3.2±0.4	Less than 2.0
B	4.5±0.5	2.0±0.3	Less than 2.0
C	4.5±0.5	1.25±0.2	Less than 1.25
D	3.2±0.4	2.5±0.3	Less than 1.5
E	3.2±0.2	1.6±0.2	Less than 1.25
F	2.0±0.3	1.25±0.2	Less than 1.25
G	1.6±0.2	0.8±0.2	Less than 1.0
H	1.0±0.05	0.5±0.05	0.5±0.05

#### Chip resistor

Code	L	W	T
E	3.2±0.2	1.6±0.2	1.0
F	2.0±0.3	1.25±0.2	1.0
G	1.6±0.2	0.8±0.2	0.5±0.1
H	1.0±0.05	0.5±0.05	0.35±0.05

### RESISTORS

#### • Chip resistor (Carbon)

- (EX)  $\frac{R}{1} \frac{D}{2} \frac{73}{3} \frac{E}{4} \frac{B}{5} \frac{2B}{6} \frac{000}{7} \frac{J}{7}$
- (Chip) (B, F)

#### • Carbon resistor (Normal type)

- (EX)  $\frac{R}{1} \frac{D}{2} \frac{14}{3} \frac{B}{4} \frac{B}{5} \frac{2C}{6} \frac{000}{7} \frac{J}{7}$

- 1 = Type
- 2 = Shape
- 3 = Dimension
- 4 = Temp. coefficient
- 5 = Rating wattage
- 6 = Value
- 7 = Tolerance

#### • Rating wattage

Code	Wattage	Code	Wattage	Code	Wattage
1J	1/16W	2C	1/6W	3A	1W
2A	1/10W	2E	1/4W	3D	2W
2B	1/8W	2H	1/2W		

# TK-8360/8360H/8360H(U)

## PARTS LIST

\* New Parts. Δ indicates safety critical components.

Parts without **Parts No.** are not supplied.

Les articles non mentionnés dans le **Parts No.** ne sont pas fournis.

Teile ohne **Parts No.** werden nicht geliefert.

L : Scandinavia

Y : PX (Far East, Hawaii)

C : China

K : USA

T : England

X : Australia

P : Canada

E : Europe

M : Other Areas

### TK-8360/8360H/8360H(U) DISPLAY UNIT (X54-3740-20)

Ref. No.	Address	New parts	Parts No.	Description	Destination
<b>TK-8360/8360H/8360H(U)</b>					
1	1B		A02-4073-21	PLASTIC CABINET	
	2B		A10-4129-01	CHASSIS	
3	3A	*	A62-1180-13	PANEL ASSY	
5	2B		B09-0732-03	CAP (D-SUB)	
7	3A	*	B43-1650-04	BADGE	
8	2D	*	B62-2278-00	INSTRUCTION MANUAL (E/R) ACCESSORY	M,M1
8	2D	*	B62-2279-00	INSTRUCTION MANUAL (E/S/F) ACCESSORY	K1,K2
10	2B		E04-0167-15	RF COAXIAL RECEPTACLE (M)	
11	2B		E23-1346-04	GROUND TERMINAL (CLIP)	
12	1C		E30-7523-55	DC CORD ASSY ACCESSORY	
13	2B		E30-7684-05	DC CORD	
14	2A		E37-1461-05	FLAT CABLE	
16	1C		F52-0023-05	FUSE (10A BLADE TYPE) ACCESSORY	M
16	1C		F52-0024-05	FUSE (15A BLADE TYPE) ACCESSORY	M1,K1,K2
18	3B		G13-2363-04	CUSHION	
19	2B		G53-1643-04	PACKING (DC CORD)	
20	2B		G53-1662-04	PACKING (RECEPTACLE)	
21	1B		G53-1819-21	PACKING (CHASSIS)	
22	2A		G53-1820-03	PACKING (PANEL)	
23	3A	*	G53-1858-03	PACKING (SP)	
25	1C,1D		H12-3178-05	PACKING FIXTURE	K1,K2
26	2D	*	H52-2310-22	ITEM CARTON CASE	K1,K2
28	3D		J19-1584-15	HOLDER (MIC)	K1,K2
29	3A	*	J19-5542-02	HOLDER (SP)	
30	1C		J29-0726-03	BRACKET ACCESSORY	
32	3A	*	K29-9479-01	KEY TOP	
A	1A,1B		N35-2604-43	BINDING HEAD MACHINE SCREW	
B	1A,1B,2B		N67-3008-48	PAN HEAD SEMS SCREW	
C	2B		N87-2608-48	BRAZIER HEAD TAPTITE SCREW	
34	3D		N99-2039-05	SCREW SET ACCESSORY	
36	3A		T07-0785-15	SPEAKER	
37	2C		T91-0624-65	MICROPHONE ACCESSORY	K1
38	2C		T91-0639-55	MICROPHONE ACCESSORY	K2
<b>DISPLAY UNIT (X54-3740-20)</b>					
101	2A	*	B11-1885-03	ILLUMINATION GUIDE	
102	2A	*	B38-0936-05	LCD	
D5-9			B30-2337-05	LED (YELLOW)	
D11-21			B30-2337-05	LED (YELLOW)	
D22	3A		B30-2321-05	LED (BLUE)	
D23	3A		B30-2151-05	LED (RED/GRN)	
D24			B30-2337-05	LED (YELLOW)	
C1			CC73HCH1H101J	CHIP C 100PF J	
C2,3			CK73HB1H221K	CHIP C 220PF K	
C4			CC73HCH1H101J	CHIP C 100PF J	
C5			CK73HB1H221K	CHIP C 220PF K	

Ref. No.	Address	New parts	Parts No.	Description	Destination
C6			CK73HB1H471K	CHIP C 470PF K	
C7			CK73HB1H102K	CHIP C 1000PF K	
C8			CK73HB1H221K	CHIP C 220PF K	
C9			CK73HB1H471K	CHIP C 470PF K	
C10			CK73HB1H102K	CHIP C 1000PF K	
C11			CK73HB1H221K	CHIP C 220PF K	
C12			CC73HCH1H101J	CHIP C 100PF J	
C13			CK73HB1E103K	CHIP C 0.010UF K	
C14,15			CK73HB1H102K	CHIP C 1000PF K	
C20			CC73HCH1H101J	CHIP C 100PF J	
C21			CK73HB1E103K	CHIP C 0.010UF K	
C22			CK73HB1H221K	CHIP C 220PF K	
C23			CK73HB1H102K	CHIP C 1000PF K	
C24			CK73HB1E103K	CHIP C 0.010UF K	
C25,26			CK73HB1H471K	CHIP C 470PF K	
C27,28			CK73HB1A105K	CHIP C 1.0UF K	
C29-31			CK73HB1H102K	CHIP C 1000PF K	
C32,33			CK73HB1C473K	CHIP C 0.047UF K	
103	2A	*	E29-1231-15	INTER CONNECTOR (LCD)	
CN1			E40-6851-05	FLAT CABLE CONNECTOR (30P)	
J1	3A		E58-0535-05	MODULAR JACK (MIC)	
104	2A	*	J21-8629-03	MOUNTING HARDWARE (LCD)	
L1			L92-0138-05	CHIP FERRITE	
CP1			RK74HB1J102J	CHIP-COM 1.0K J 1/16W	
R1			RK73HB1J100J	CHIP R 10 J 1/16W	
R2-4			RK73HB1J103J	CHIP R 10K J 1/16W	
R5			RK73HB1J102J	CHIP R 1.0K J 1/16W	
R6			RK73HB1J150J	CHIP R 15 J 1/16W	
R7			RK73HB1J000J	CHIP R 0.0 J 1/16W	
R8			RK73FB2B100J	CHIP R 10 J 1/8W	
R9			RK73HB1J000J	CHIP R 0.0 J 1/16W	
R12			RK73HB1J101J	CHIP R 100 J 1/16W	
R14			RK73HB1J122J	CHIP R 1.2K J 1/16W	
R15			RK73HB1J000J	CHIP R 0.0 J 1/16W	
R17			RK73HB1J000J	CHIP R 0.0 J 1/16W	
R18			RK73HB1J181J	CHIP R 180 J 1/16W	
R19			RK73HB1J820J	CHIP R 82 J 1/16W	
R20			RK73HB1J000J	CHIP R 0.0 J 1/16W	
R22			RK73HB1J000J	CHIP R 0.0 J 1/16W	
R23			RK73HB1J473J	CHIP R 47K J 1/16W	
R24,25			RK73HB1J103J	CHIP R 10K J 1/16W	
R26			RK73HB1J123J	CHIP R 12K J 1/16W	
R27			RK73HB1J473J	CHIP R 47K J 1/16W	
R28,29			RK73HB1J151J	CHIP R 150 J 1/16W	
R30,31			RK73HB1J121J	CHIP R 120 J 1/16W	
R32			RK73HB1J103J	CHIP R 10K J 1/16W	
R33			RK73HB1J000J	CHIP R 0.0 J 1/16W	
R34-37			RK73HB1J151J	CHIP R 150 J 1/16W	
D1			UDZW6.2(B)	ZENER DIODE	
D2			DA221	DIODE	
D10			MC2850	DIODE	
IC1		*	LC75857W-E	MOS-IC	
Q2,3			RT1N141U-T111	TRANSISTOR	

## PARTS LIST

DISPLAY UNIT (X54-3740-20)

TX-RX UNIT (X57-8020-XX)

Ref. No.	Address	New parts	Parts No.	Description	Desti-nation	Ref. No.	Address	New parts	Parts No.	Description	Desti-nation
Q4,5			RT1P141U-T111	TRANSISTOR		C83,84			CC73HCH1H101J	CHIP C 100PF J	
Q6			RT1N141U-T111	TRANSISTOR		C85,86			CK73GB1H471K	CHIP C 470PF K	
Q7			KRA225S	TRANSISTOR		C87			CC73HCH1H3R5B	CHIP C 3.5PF B	
Q8		*	RT1N141C-T112	TRANSISTOR		C88			CC73HCH1H020B	CHIP C 2.0PF B	M
Q9			RN47A4-F	TRANSISTOR		C88			CC73HCH1H2R5B	CHIP C 2.5PF B	M1,K1,K2
Q10			2SB1132(Q,R)	TRANSISTOR		C89,90			CK73GB1H471K	CHIP C 470PF K	
						C91			CC73HCH1H060B	CHIP C 6.0PF B	
						C92			CC73HCH1H080B	CHIP C 8.0PF B	
						C93			CC73HCH1H040B	CHIP C 4.0PF B	
						C94			CC73HCH1H060B	CHIP C 6.0PF B	
<b>TX-RX UNIT (X57-8020-XX) -11: K1,K2,M1 -22: M</b>											
C1			CK73HB1H471K	CHIP C 470PF K		C95			CK73HB1H471K	CHIP C 470PF K	
C2			CC73HCH1H020B	CHIP C 2.0PF B		C96			CC73HCH1H0R3B	CHIP C 0.3PF B	
C5,6			CC73HCH1H101J	CHIP C 100PF J		C97			CC73HCH1H0R5B	CHIP C 0.5PF B	
C7			CK73HB1H102K	CHIP C 1000PF K		C98			CS77B21C100M	CHIP TNL 10UF 16WV	
C8,9			CK73HB1A104K	CHIP C 0.10UF K		C99-101			CK73HB1H471K	CHIP C 470PF K	
C10			CC73HCH1H101J	CHIP C 100PF J		C102			CC73HCH1H040B	CHIP C 4.0PF B	
C11			CC73GCH1H101J	CHIP C 100PF J		C103			CC73HCH1H020B	CHIP C 2.0PF B	
C12			CC73HCH1H200J	CHIP C 20PF J		C104			CC73GCH1H020B	CHIP C 2.0PF B	
C14			CC73HCH1H101J	CHIP C 100PF J		C105-107			CK73HB1H471K	CHIP C 470PF K	
C16			CC73HCH1H101J	CHIP C 100PF J		C109			CK73HB1H471K	CHIP C 470PF K	
C17			CC73HCH1H080B	CHIP C 8.0PF B		C110			CC73GCH1H020B	CHIP C 2.0PF B	
C19			CK73FBJ106K	CHIP C 10UF K		C111			CK73HB1E103K	CHIP C 0.010UF K	
C21			CK73HB1A104K	CHIP C 0.10UF K		C112,113			CK73HB1H471K	CHIP C 470PF K	
C22			CK73HBJ105K	CHIP C 1.0UF K		C114			CK73FBJ226M	CHIP C 22UF M	
C23,24			CK73HB1A104K	CHIP C 0.10UF K		C300			CC73GCH1H110J	CHIP C 11PF J	
C25			CK73FBJ106K	CHIP C 10UF K		C301			CC73HCH1H060B	CHIP C 6.0PF B	
C27			CK73HB1A104K	CHIP C 0.10UF K		C302			CC73HCH1H110J	CHIP C 11PF J	
C28			CK73FBJ106K	CHIP C 10UF K		C303			CK73HB1H471K	CHIP C 470PF K	
C29			CK73HB1H471K	CHIP C 470PF K		C304			CC73HCH1H240J	CHIP C 24PF J	
C30			CK73HB1E103K	CHIP C 0.010UF K		C305			CK73HB1H102K	CHIP C 1000PF K	
C31			CK73HB1A104K	CHIP C 0.10UF K		C308			CC73HCH1H110J	CHIP C 11PF J	
C32,33			CK73HB1H471K	CHIP C 470PF K		C309			CK73HB1H471K	CHIP C 470PF K	
C35			CC73HCH1H3R5B	CHIP C 3.5PF B		C310			CC73HCH1H1R5B	CHIP C 1.5PF B	
C36			CK73HB1H471K	CHIP C 470PF K		C311			CK73HB1E223K	CHIP C 0.022UF K	
C42			CS77CA1V0R1M	CHIP TNL 0.1UF 35WV		C312			CC73GCH1H271J	CHIP C 270PF J	
C43			CC73HCH1H101J	CHIP C 100PF J		C314			CC73GCH1H101J	CHIP C 100PF J	M1,K1,K2
C44			CC73HCH1H020B	CHIP C 2.0PF B		C314			CK73GB1H471K	CHIP C 470PF K	M
C47			CK73HB1H471K	CHIP C 470PF K		C319			CK73HB1H471K	CHIP C 470PF K	
C48			C92-0588-05	CHIP TNL 1.5UF 16WV		C321			CC73HCH1H101J	CHIP C 100PF J	M
C49			CC73HCH1H050B	CHIP C 5.0PF B		C322			CK73GB1H221K	CHIP C 220PF K	
C50			CK73GB1H471K	CHIP C 470PF K		C324			CC73GCH1H220J	CHIP C 22PF J	
C52			CC73HCH1H330J	CHIP C 33PF J		C325			CK73GB1H102K	CHIP C 1000PF K	
C53			CC73HCH1H020B	CHIP C 2.0PF B		C326,327			CC73GCH1H101J	CHIP C 100PF J	
C56			CC73HCH1H3R5B	CHIP C 3.5PF B		C328			CK73HB1A104K	CHIP C 0.10UF K	M
C57			C92-0863-05	CHIP TNL 0.047UF 35WV		C328			CK73HB1A154K	CHIP C 0.15UF K	M1,K1,K2
C59			CK73HB1H471K	CHIP C 470PF K		C330			CK73GB1H471K	CHIP C 470PF K	
C61			C92-0863-05	CHIP TNL 0.047UF 35WV		C331			CC73GCH1H101J	CHIP C 100PF J	
C63			C93-0787-05	CHIP C 0.1UF J		C332			CK73GB1H471K	CHIP C 470PF K	
C65			CK73HB1A104K	CHIP C 0.10UF K		C333			CC73GCH1H470J	CHIP C 47PF J	
C66			CK73HB1H471K	CHIP C 470PF K		C334			CC73GCH1H220J	CHIP C 22PF J	
C68			CC73HCH1H470J	CHIP C 47PF J		C335			C93-0553-05	CHIP C 3.0PF C	
C70			CC73HCH1H470J	CHIP C 47PF J		C338			CK73HB1A104K	CHIP C 0.10UF K	
C72			CK73HB1H471K	CHIP C 470PF K		C339			CK73GB1H471K	CHIP C 470PF K	
C74			CK73HB1H471K	CHIP C 470PF K		C342			CK73HB1H471K	CHIP C 470PF K	
C75			CK73FBJ106K	CHIP C 10UF K		C343			CK73GB1H471K	CHIP C 470PF K	
C77			CC73HCH1H100C	CHIP C 10PF C		C345			CK73GB1H103K	CHIP C 0.010UF K	
C79			CC73HCH1H160J	CHIP C 16PF J		C346,347			CK73HB1H471K	CHIP C 470PF K	
C80			CC73HCH1H101J	CHIP C 100PF J		C348			CK73GB1H103K	CHIP C 0.010UF K	
C81			CC73HCH1H0R5B	CHIP C 0.5PF B		C349			CK73HB1H471K	CHIP C 470PF K	
C82			CC73HCH1HR75B	CHIP C 0.75PF B		C350			CC73GCH1H3R5B	CHIP C 3.5PF B	

K1: TK-8360H K K2: TK-8360H(U) K

M: TK-8360 M M1: TK-8360H M

## PARTS LIST

## TX-RX UNIT (X57-8020-XX)

Ref. No.	Address	New parts	Parts No.	Description	Destination	Ref. No.	Address	New parts	Parts No.	Description	Destination
C351			C93-0550-05	CHIP C 1.0PF C	M1,K1,K2	C506			CC73HCH1H160J	CHIP C 16PF J	
C351			C93-0554-05	CHIP C 4.0PF C	M	C508			CC73HCH1H470J	CHIP C 47PF J	
C352,353			C93-0603-05	CHIP C 1000PF K		C509			CK73HB1E103K	CHIP C 0.010UF K	
C354			CC73GCH1H090B	CHIP C 9.0PF B	M1,K1,K2	C510-515			CK73HB1A104K	CHIP C 0.10UF K	
C354			CC73GCH1H110G	CHIP C 11PF G	M	C517			CK73HB1H471K	CHIP C 470PF K	
C355			CC73GCH1H150J	CHIP C 15PF J	M1,K1,K2	C518			CK73HB1E103K	CHIP C 0.010UF K	
C355			CC73GCH1H200J	CHIP C 20PF J	M	C519			CK73HB1H221K	CHIP C 220PF K	
C356			C93-0552-05	CHIP C 2.0PF C	M1,K1,K2	C520			CK73FB0J106K	CHIP C 10UF K	
C356			C93-0556-05	CHIP C 6.0PF D	M	C521			CK73HB1H221K	CHIP C 220PF K	
C357			C93-0550-05	CHIP C 1.0PF C	M1,K1,K2	C522,523			CK73HB1A104K	CHIP C 0.10UF K	
C357			C93-0552-05	CHIP C 2.0PF C	M	C524			CK73GB1C104K	CHIP C 0.10UF K	
C358			CM73F2H040D	CHIP C 4.0PF D	M1,K1,K2	C525			CK73HB1H102K	CHIP C 1000PF K	
C358			CM73F2H060D	CHIP C 6.0PF D	M	C527			CK73HB1E562K	CHIP C 5600PF K	
C361			C93-0550-05	CHIP C 1.0PF C	M1,K1,K2	C528			CC73HCH1H820J	CHIP C 82PF J	
C363			C93-0552-05	CHIP C 2.0PF C	M	C529			CC73HCH1H330J	CHIP C 33PF J	
C363			C93-0553-05	CHIP C 3.0PF C	M1,K1,K2	C530			CK73HB1E103K	CHIP C 0.010UF K	
C364			CK73GB1H102K	CHIP C 1000PF K		C531			CK73HB1A104K	CHIP C 0.10UF K	
C366			CK73GB1H102K	CHIP C 1000PF K		C532			CK73HB1H471K	CHIP C 470PF K	
C367			CK73HB1H102K	CHIP C 1000PF K		C533			CK73HB1A104K	CHIP C 0.10UF K	
C401			CK73HB1A104K	CHIP C 0.10UF K		C535			CK73HB1H102K	CHIP C 1000PF K	
C402			CK73HB1E103K	CHIP C 0.010UF K		C536			CC73HCH1H050B	CHIP C 5.0PF B	
C404			CS77BB21C220M	CHIP TNTL 22UF 16WV		C537			CK73HB1A104K	CHIP C 0.10UF K	
C406			CS77BB21C220M	CHIP TNTL 22UF 16WV		C538			CK73HB1H471K	CHIP C 470PF K	
C407			CK73HB1A104K	CHIP C 0.10UF K		C540			CK73HB1H102K	CHIP C 1000PF K	
C410-412			CK73HB1A104K	CHIP C 0.10UF K		C541,542			CK73HB1E103K	CHIP C 0.010UF K	
C414			CK73HB0J105K	CHIP C 1.0UF K		C543			CK73HB1E223K	CHIP C 0.022UF K	
C415			CK73GB1H102K	CHIP C 1000PF K		C544			CC73HCH1H010B	CHIP C 1.0PF B	
C416,417			CK73HB1H102K	CHIP C 1000PF K		C545			CC73HCH1H150J	CHIP C 15PF J	
C418			CK73GB1A105K	CHIP C 1.0UF K		C546			CC73HCH1H100D	CHIP C 10PF D	
C419			CK73GB1H102K	CHIP C 1000PF K		C549			CK73HB0J224K	CHIP C 0.22UF K	
C420			CS77BA1A100M	CHIP TNTL 10UF 10WV		C550			CK73HB1A104K	CHIP C 0.10UF K	
C421			CK73HB1H102K	CHIP C 1000PF K		C551			CK73HB1E103K	CHIP C 0.010UF K	
C422			CK73HB1E103K	CHIP C 0.010UF K		C552			CK73HB1H471K	CHIP C 470PF K	
C423,424			CK73GB1H102K	CHIP C 1000PF K		C553			CC73HCH1H130J	CHIP C 13PF J	
C425			CK73HB1E103K	CHIP C 0.010UF K		C554			CC73HCH1H030B	CHIP C 3.0PF B	
C426			CK73GB1A105K	CHIP C 1.0UF K		C555			CK73HB1E103K	CHIP C 0.010UF K	
C427			CK73HB1H102K	CHIP C 1000PF K		C556			CK73HB1H471K	CHIP C 470PF K	
C428			CK73FB1E225K	CHIP C 2.2UF K		C557			CK73GB1H471K	CHIP C 470PF K	
C429			CK73EB1E106K	CHIP C 10UF K		C558			CK73HB1H471K	CHIP C 470PF K	
C430			CK73HB1H102K	CHIP C 1000PF K		C559			CK73HB1E103K	CHIP C 0.010UF K	
C433			CK73HB1A104K	CHIP C 0.10UF K		C560			CK73HB1H471K	CHIP C 470PF K	
C434			CK73GB1H102K	CHIP C 1000PF K		C561			CC73HCH1H040B	CHIP C 4.0PF B	
C435			CK73GB1H221K	CHIP C 220PF K		C562,563			CK73HB1H471K	CHIP C 470PF K	
C436			CK73GB1H471K	CHIP C 470PF K		C565			CK73HB1H471K	CHIP C 470PF K	
C437			CC73GCH1H220J	CHIP C 22PF J		C566			CC73HCH1H150J	CHIP C 15PF J	
C438			CK73GB1H471K	CHIP C 470PF K		C567			CC73HCH1H030B	CHIP C 3.0PF B	
C439			CC73GCH1H470J	CHIP C 47PF J		C568			CC73HCH1HR75B	CHIP C 0.75PF B	
C440			CK73GB1H471K	CHIP C 470PF K		C569			CC73HCH1H0R5B	CHIP C 0.5PF B	
C442			CC73GCH1H101J	CHIP C 100PF J		C570			CC73HCH1H4R5B	CHIP C 4.5PF B	
C443			CK73GB1H102K	CHIP C 1000PF K		C571			CC73HCH1H150J	CHIP C 15PF J	
C444			CK73HB1A334K	CHIP C 0.33UF K		C572			CC73HCH1H1R5B	CHIP C 1.5PF B	
C445			CC73GCH1H470J	CHIP C 47PF J		C573			CK73HB1H102K	CHIP C 1000PF K	
C446			CK73GB1H471K	CHIP C 470PF K		C574			CC73HCH1H010B	CHIP C 1.0PF B	
C447			CK73GB1H221K	CHIP C 220PF K		C575			CC73HCH1H150J	CHIP C 15PF J	
C448			CK73GB1H471K	CHIP C 470PF K		C578			CC73HCH1H2R5B	CHIP C 2.5PF B	
C449			CK73HB1H102K	CHIP C 1000PF K		C579,580			CK73HB1H471K	CHIP C 470PF K	
C500			CC73HCH1H470J	CHIP C 47PF J		C582			CK73HB1A104K	CHIP C 0.10UF K	
C502			CC73HCH1H101J	CHIP C 100PF J		C583			CK73HB1H471K	CHIP C 470PF K	
C504			CK73HB1E103K	CHIP C 0.010UF K		C585-589			CK73HB1H471K	CHIP C 470PF K	
C505			CC73HCH1H470J	CHIP C 47PF J		C590			CC73HCH1H2R5B	CHIP C 2.5PF B	



## PARTS LIST

TX-RX UNIT (X57-8020-XX)

Ref. No.	Address	New parts	Parts No.	Description	Desti-nation	Ref. No.	Address	New parts	Parts No.	Description	Desti-nation
C591			CC73GCH1H471J	CHIP C 470PF J	M	C777			CK73HB1A104K	CHIP C 0.10UF K	
C592			CC73HCH1H150J	CHIP C 15PF J		C778			CK73HB0J105K	CHIP C 1.0UF K	
C593			CC73HCH1H1R5B	CHIP C 1.5PF B		C779			CK73HB1A104K	CHIP C 0.10UF K	
C594			CK73HB1H102K	CHIP C 1000PF K		C780			CK73GB0J475K	CHIP C 4.7UF K	
C595			CC73HCH1H2R5B	CHIP C 2.5PF B		C784			CK73HB1A104K	CHIP C 0.10UF K	
C596			CC73HCH1H150J	CHIP C 15PF J		C785			CK73HB1C333K	CHIP C 0.033UF K	
C597			CC73HCH1H040B	CHIP C 4.0PF B		C786			CC73HCH1H121J	CHIP C 120PF J	
C600			CC73HCH1H300J	CHIP C 30PF J		C788			CK73HB1H102K	CHIP C 1000PF K	
C602			CC73HCH1H040B	CHIP C 4.0PF B		C790			CK73GB0J106K	CHIP C 10UF K	
C603			CC73HCH1H030B	CHIP C 3.0PF B		C791			CK73HB1A104K	CHIP C 0.10UF K	
C605			CC73HCH1H040B	CHIP C 4.0PF B		C792			CC73HCH1H391J	CHIP C 390PF J	
C607			CK73HB1H471K	CHIP C 470PF K		C793			CK73HB1H471K	CHIP C 470PF K	
C700-704			CC73HCH1H101J	CHIP C 100PF J		C794			CK73HB1A104K	CHIP C 0.10UF K	
C705			CK73HB1H471K	CHIP C 470PF K		C795			CK73HB0J105K	CHIP C 1.0UF K	
C706			CC73HCH1H101J	CHIP C 100PF J		C796			CK73HB1E103K	CHIP C 0.010UF K	
C707,708			CK73HB1H471K	CHIP C 470PF K		C797			CK73HB1A104K	CHIP C 0.10UF K	
C709			CC73HCH1H101J	CHIP C 100PF J		C799-801			CK73HB1A104K	CHIP C 0.10UF K	
C710			CK73HB1H471K	CHIP C 470PF K		C802			CK73HB1E103K	CHIP C 0.010UF K	
C712			CK73HB1H471K	CHIP C 470PF K		C803			CK73HB0J105K	CHIP C 1.0UF K	
C714			CK73HB1H471K	CHIP C 470PF K		C804			CK73GB0J106K	CHIP C 10UF K	
C716			CK73HB1H471K	CHIP C 470PF K		C807			CK73GB1C104K	CHIP C 0.10UF K	
C717			CC73HCH1H101J	CHIP C 100PF J		C808			CK73GB1H471K	CHIP C 470PF K	
C718			CK73HB1H471K	CHIP C 470PF K		C809			CK73HB0J105K	CHIP C 1.0UF K	
C720			CK73HB1H471K	CHIP C 470PF K		C810			CC73HCH1H101J	CHIP C 100PF J	
C722			CK73HB1H471K	CHIP C 470PF K		C811			CK73FB0J106K	CHIP C 10UF K	
C723			CC73HCH1H101J	CHIP C 100PF J		C812			CK73HB0J105K	CHIP C 1.0UF K	
C724			CK73HB1H471K	CHIP C 470PF K		C813			CC73HCH1H101J	CHIP C 100PF J	
C726			CK73HB1H471K	CHIP C 470PF K		C814			CK73HB0J105K	CHIP C 1.0UF K	
C728			CK73HB1H471K	CHIP C 470PF K		C815			CC73HCH1H151J	CHIP C 150PF J	
C730			CK73HB1H471K	CHIP C 470PF K		C816			CK73HB0J105K	CHIP C 1.0UF K	
C732			CK73HB1H471K	CHIP C 470PF K		C818			CK73FB0J106K	CHIP C 10UF K	
C734			CK73HB1H471K	CHIP C 470PF K		C819			CK73HB1E103K	CHIP C 0.010UF K	
C735			CC73HCH1H101J	CHIP C 100PF J		C820			CK73GB1H104K	CHIP C 0.10UF K	
C736			CK73HB1H471K	CHIP C 470PF K		C821			CK73GB0J106K	CHIP C 10UF K	
C738			CK73HB1H471K	CHIP C 470PF K		C822			CK73FB0J226M	CHIP C 22UF M	
C739			CC73HCH1H101J	CHIP C 100PF J		C823			CK73GB1A105K	CHIP C 1.0UF K	
C740			CK73HB1H471K	CHIP C 470PF K		C824			CK73HB1H102K	CHIP C 1000PF K	
C742,743			CC73HCH1H470J	CHIP C 47PF J		C826			CK73HB1A683K	CHIP C 0.068UF K	
C744			CK73HB1H471K	CHIP C 470PF K		C829			CK73HB1H682K	CHIP C 6800PF K	
C745			CC73HCH1H470J	CHIP C 47PF J		C832			CK73GB1H102K	CHIP C 1000PF K	
C746			CK73HB1H471K	CHIP C 470PF K		C834			CK73HB1H332K	CHIP C 3300PF K	
C747			CK73GB1H102K	CHIP C 1000PF K		C836			CK73HB1E103K	CHIP C 0.010UF K	
C748			CK73GB1A105K	CHIP C 1.0UF K		C840,841			CK73HB1H471K	CHIP C 470PF K	M
C749			CK73HB0J105K	CHIP C 1.0UF K		C841			CK73HB1H471K	CHIP C 470PF K	M1,K1,K2
C752			CK73HB0J105K	CHIP C 1.0UF K		C842			CK73GB1H102K	CHIP C 1000PF K	
C754			CK73GB1H102K	CHIP C 1000PF K		C843			CK73HB0J105K	CHIP C 1.0UF K	
C755			CK73HB0J105K	CHIP C 1.0UF K		C844			CK73HB1H102K	CHIP C 1000PF K	
C756			CK73GB1C104K	CHIP C 0.10UF K		C848			CC73HCH1H180G	CHIP C 18PF G	
C758			CK73HB1A104K	CHIP C 0.10UF K		C849			CC73HCH1H0R3B	CHIP C 0.3PF B	
C761			CK73HB1H471K	CHIP C 470PF K		C851			CC73HCH1H180G	CHIP C 18PF G	
C762,763			CK73GB1E105K	CHIP C 1.0UF K		C852			CK73HB1H102K	CHIP C 1000PF K	
C764			CK73HB1A104K	CHIP C 0.10UF K		C853			CK73HB1A105K	CHIP C 1.0UF K	
C765			CK73FB0J106K	CHIP C 10UF K		C854			CK73GB1C104K	CHIP C 0.10UF K	
C766			CK73HB1A104K	CHIP C 0.10UF K		C855			CK73GB1H102K	CHIP C 1000PF K	
C767,768			CK73GB1E105K	CHIP C 1.0UF K		C858-861			CK73HB1H102K	CHIP C 1000PF K	
C769			CK73HB1A104K	CHIP C 0.10UF K		C862,863			CK73GB1A105K	CHIP C 1.0UF K	
C771			CC73HCH1H680J	CHIP C 68PF J		C864,865			CK73HB0J105K	CHIP C 1.0UF K	
C772			CK73HB1A104K	CHIP C 0.10UF K		C866			CK73HB1A224K	CHIP C 0.22UF K	
C773			CK73HB0J105K	CHIP C 1.0UF K		C867			CK73GB1C224K	CHIP C 0.22UF K	
C774,775			CK73HB1A104K	CHIP C 0.10UF K		C869			CK73HB1H102K	CHIP C 1000PF K	

K1: TK-8360H K K2: TK-8360H(U) K  
M: TK-8360 M M1: TK-8360H M

## PARTS LIST

## TX-RX UNIT (X57-8020-XX)

Ref. No.	Address	New parts	Parts No.	Description	Destination	Ref. No.	Address	New parts	Parts No.	Description	Destination
C871			CS77BA1C4R7M	CHIP TNTL 4.7UF 16WV		L310			L34-4902-05	AIR-CORE COIL (9.5T)	
C872			C92-0873-05	ELECTRO 47UF 16WV		L311			L34-1039-05	AIR-CORE COIL (1.5T)	M1,K1,K2
C873			CE32BD1C471M	CHIP EL 470UF 16WV		L311			L34-1113-05	AIR-CORE COIL (1.5T)	M
C874			CK73HB1H102K	CHIP C 1000PF K		L313			L34-1039-05	AIR-CORE COIL (1.5T)	
C875			CE32BD1C471M	CHIP EL 470UF 16WV		L314,315			L34-1113-05	AIR-CORE COIL (1.5T)	
C876			CC73HCH1H220J	CHIP C 22PF J		L316			L34-4902-05	AIR-CORE COIL (9.5T)	
C877			CC73HCH1H470J	CHIP C 47PF J		L500,501			L40-4781-86	SMALL FIXED INDUCTOR (0.47UH)	
C880			CC73HCH1H101J	CHIP C 100PF J		L503			L40-4781-86	SMALL FIXED INDUCTOR (0.47UH)	
C881			CK73HB1H471K	CHIP C 470PF K		L504			L40-1875-71	SMALL FIXED INDUCTOR (18NH)	
C882			CC73HCH1H220J	CHIP C 22PF J		L508			L40-1875-71	SMALL FIXED INDUCTOR (18NH)	
C883			CK73HB1H471K	CHIP C 470PF K		L509			L41-2785-39	SMALL FIXED INDUCTOR (0.27UH)	
C884			CC73HCH1H220J	CHIP C 22PF J		L510			L41-6885-39	SMALL FIXED INDUCTOR (0.68UH)	
C885			CK73HB1H471K	CHIP C 470PF K		L512-514			L41-6868-14	SMALL FIXED INDUCTOR (6.8NH)	
C886			CK73HB1A104K	CHIP C 0.10UF K		L515			L41-2788-45	SMALL FIXED INDUCTOR (270NH)	
C887			CK73HB1E103K	CHIP C 0.010UF K		L516			L40-1875-92	SMALL FIXED INDUCTOR (18NH)	
C888,889			CK73HB1H471K	CHIP C 470PF K		L518,519			L41-6868-14	SMALL FIXED INDUCTOR (6.8NH)	
C890			CC73HCH1H121J	CHIP C 120PF J		L523			L41-8275-45	SMALL FIXED INDUCTOR (82NH)	
C891			CK73HB1A104K	CHIP C 0.10UF K		L700,701			L92-0163-05	BEADS CORE	
C893			CK73HB1A104K	CHIP C 0.10UF K		L702			L92-0443-05	CHIP FERRITE	
C894			CK73HB1H103K	CHIP C 0.010UF K		L704			L92-0443-05	CHIP FERRITE	
C895			CK73HB1H102K	CHIP C 1000PF K		L706			L92-0161-05	BEADS CORE	
C896			CK73HB1E103K	CHIP C 0.010UF K		L707-712			L92-0163-05	BEADS CORE	
C897			CK73HB1H471K	CHIP C 470PF K	M	X1			L77-3055-05	TCXO (19.2MHZ)	
C900			CC73HCH1H101J	CHIP C 100PF J		X700			L77-1950-05	CRYSTAL RESONATOR (11.0592MHZ)	
C902			CC73HCH1H101J	CHIP C 100PF J		XF500			L71-0659-05	MCF (38.85MHZ)	
CN700			E40-6361-05	PIN ASSY (26P)		CP700-703			RK74HA1J102J	CHIP-COM 1.0K J 1/16W	
CN701			E40-6847-05	FLAT CABLE CONNECTOR (30P)		CP704			RK74HA1J101J	CHIP-COM 100 J 1/16W	
J700	1B		E58-0536-05	D-SUB SOCKET (ACC)		R1			RK73HB1J473J	CHIP R 47K J 1/16W	
J701	1B		E11-0425-05	3.5D PHONE JACK (EXT-SP)		R3			RK73HB1J100J	CHIP R 10 J 1/16W	
F400			F53-0327-15	FUSE (4A)		R5			RK73HB1J103J	CHIP R 10K J 1/16W	
CD500			L79-1866-05	TUNING COIL (450KHZ)		R6-8			RK73HB1J102J	CHIP R 1.0K J 1/16W	
CF500			L72-0993-05	CERAMIC FILTER (450KHZ/WID)		R9			RK73HB1J000J	CHIP R 0.0 J 1/16W	
CF501			L72-0999-05	CERAMIC FILTER (450KHZ/NAR)		R10			RK73HB1J152J	CHIP R 1.5K J 1/16W	
L2			L41-1591-08	SMALL FIXED INDUCTOR (1.5NH)		R11			RK73HB1J223J	CHIP R 22K J 1/16W	
L3			L92-0442-05	CHIP FERRITE		R12			RK73HB1J000J	CHIP R 0.0 J 1/16W	
L5			L40-1575-71	SMALL FIXED INDUCTOR (15NH)		R13			RK73HB1J563J	CHIP R 56K J 1/16W	
L8			L40-1575-71	SMALL FIXED INDUCTOR (15NH)		R14			RK73HB1J000J	CHIP R 0.0 J 1/16W	
L9			L92-0443-05	CHIP FERRITE		R15			RK73HB1J104J	CHIP R 100K J 1/16W	
L11			L40-2785-92	SMALL FIXED INDUCTOR (270NH)		R16			RK73HB1J561J	CHIP R 560 J 1/16W	
L13			L40-2785-92	SMALL FIXED INDUCTOR (270NH)		R17			RK73HB1J100J	CHIP R 10 J 1/16W	
L15,16			L92-0163-05	BEADS CORE		R19,20			RK73HB1J000J	CHIP R 0.0 J 1/16W	
L19			L40-2285-92	SMALL FIXED INDUCTOR (220NH)		R21			RK73HB1J100J	CHIP R 10 J 1/16W	
L22-24			L40-2285-92	SMALL FIXED INDUCTOR (220NH)		R22			RK73HB1J102J	CHIP R 1.0K J 1/16W	
L26			L40-2285-92	SMALL FIXED INDUCTOR (220NH)		R23			RK73HB1J100J	CHIP R 10 J 1/16W	
L28			L40-2285-92	SMALL FIXED INDUCTOR (220NH)		R24			RK73HB1J183J	CHIP R 18K J 1/16W	
L29			L92-0443-05	CHIP FERRITE		R25			RK73HB1J560J	CHIP R 56 J 1/16W	
L31,32			L41-2278-14	SMALL FIXED INDUCTOR (22NH)		R26			RK73HB1J000J	CHIP R 0.0 J 1/16W	
L33			L40-2702-86	SMALL FIXED INDUCTOR (27UH)		R30			RK73HB1J472J	CHIP R 4.7K J 1/16W	
L35			L40-2785-92	SMALL FIXED INDUCTOR (270NH)		R33,34			RK73HB1J000J	CHIP R 0.0 J 1/16W	
L37			L40-2785-92	SMALL FIXED INDUCTOR (270NH)		R36			RK73HB1J102J	CHIP R 1.0K J 1/16W	
L39			L40-2702-86	SMALL FIXED INDUCTOR (27UH)		R39,40			RK73HB1J000J	CHIP R 0.0 J 1/16W	
L40			L92-0443-05	CHIP FERRITE		R41			RK73HB1J223J	CHIP R 22K J 1/16W	
L41,42			L40-3375-71	SMALL FIXED INDUCTOR (33NH)		R42			RK73HB1J272J	CHIP R 2.7K J 1/16W	
L300			L40-8265-71	SMALL FIXED INDUCTOR (8.2NH)		R44			RK73HB1J153J	CHIP R 15K J 1/16W	
L301		*	L40-4763-71	SMALL FIXED INDUCTOR (4.7NH)		R45			RK73HB1J102J	CHIP R 1.0K J 1/16W	
L302			L40-1075-92	SMALL FIXED INDUCTOR (10NH)		R46,47			RK73HB1J000J	CHIP R 0.0 J 1/16W	
L303			L40-1575-92	SMALL FIXED INDUCTOR (15NH)		R50			RK73HB1J225J	CHIP R 2.2M J 1/16W	
L304,305			L40-1275-92	SMALL FIXED INDUCTOR (12NH)		R51			RK73HB1J000J	CHIP R 0.0 J 1/16W	
L307-309			L92-0179-05	CHIP FERRITE		R52			RK73HB1J182J	CHIP R 1.8K J 1/16W	
						R53			RK73FB2B102J	CHIP R 1.0K J 1/8W	

## PARTS LIST

TX-RX UNIT (X57-8020-XX)

Ref. No.	Address	New parts	Parts No.	Description	Desti-nation	Ref. No.	Address	New parts	Parts No.	Description	Desti-nation
R54,55			RK73HB1J000J	CHIP R 0.0 J 1/16W		R346			RK73GB2A102J	CHIP R 1.0K J 1/10W	
R56,57			RK73HB1J103J	CHIP R 10K J 1/16W		R348-351			RK73GB2A000J	CHIP R 0.0 J 1/10W	
R58,59			RK73HB1J000J	CHIP R 0.0 J 1/16W		R352			RK73GH2A121D	CHIP R 120 D 1/10W	M1,K1,K2
R61			RK73HB1J000J	CHIP R 0.0 J 1/16W		R352			RK73GH2A221D	CHIP R 220 D 1/10W	M
R62			RK73HB1J473J	CHIP R 47K J 1/16W		R353			RK73GH2A181D	CHIP R 180 D 1/10W	
R63			RK73HB1J000J	CHIP R 0.0 J 1/16W		R358	2B		R92-1061-05	JUMPER REST 0 OHM	
R64,65			RK73HB1J393J	CHIP R 39K J 1/16W		R400			RK73HB1J103J	CHIP R 10K J 1/16W	
R66			RK73HB1J473J	CHIP R 47K J 1/16W		R401			RK73HB1J472J	CHIP R 4.7K J 1/16W	
R67			RN73HH1J391D	CHIP R 390 D 1/16W		R402			RK73HB1J152J	CHIP R 1.5K J 1/16W	
R68			RN73HH1J561D	CHIP R 560 D 1/16W		R403,404			RK73HB1J473J	CHIP R 47K J 1/16W	
R69			RK73GB2A104J	CHIP R 100K J 1/10W		R405,406			RK73HB1J104J	CHIP R 100K J 1/16W	
R70			RK73HB1J472J	CHIP R 4.7K J 1/16W		R407			RK73HB1J102J	CHIP R 1.0K J 1/16W	
R71			RN73HH1J680D	CHIP R 68 D 1/16W		R408			RK73GB2A221J	CHIP R 220 J 1/10W	
R72			RN73HH1J101D	CHIP R 100 D 1/16W		R409			RK73GB2A473J	CHIP R 47K J 1/10W	
R73			RK73HB1J102J	CHIP R 1.0K J 1/16W		R410			RK73GB2A334J	CHIP R 330K J 1/10W	
R74,75			RK73HB1J000J	CHIP R 0.0 J 1/16W		R411			RK73HB1J474J	CHIP R 470K J 1/16W	
R76			RK73HB1J124J	CHIP R 120K J 1/16W	M1,K1,K2	R412			RK73HB1J564J	CHIP R 560K J 1/16W	
R76			RK73HB1J563J	CHIP R 56K J 1/16W	M	R413			RK73HB1J000J	CHIP R 0.0 J 1/16W	
R77			RK73HB1J000J	CHIP R 0.0 J 1/16W		R414			RK73HB1J474J	CHIP R 470K J 1/16W	
R78			RK73HB1J101J	CHIP R 100 J 1/16W		R500			RK73HB1J000J	CHIP R 0.0 J 1/16W	
R80			RK73HB1J124J	CHIP R 120K J 1/16W	M	R502			RK73HB1J824J	CHIP R 820K J 1/16W	
R80			RK73HB1J683J	CHIP R 68K J 1/16W	M1,K1,K2	R503			RK73HB1J101J	CHIP R 100 J 1/16W	
R81			RK73HB1J101J	CHIP R 100 J 1/16W	M	R504-508			RK73HB1J103J	CHIP R 10K J 1/16W	
R81,82			RK73HB1J101J	CHIP R 100 J 1/16W	M1,K1,K2	R510			RK73HB1J103J	CHIP R 10K J 1/16W	
R82			RK73HB1J100J	CHIP R 10 J 1/16W	M	R511			RK73GB2A100J	CHIP R 10 J 1/10W	
R83			RK73HB1J102J	CHIP R 1.0K J 1/16W		R512			RK73HB1J182J	CHIP R 1.8K J 1/16W	
R84			RK73HB1J000J	CHIP R 0.0 J 1/16W		R513			RK73HB1J104J	CHIP R 100K J 1/16W	
R85			RK73HB1J222J	CHIP R 2.2K J 1/16W		R515			RK73HB1J564J	CHIP R 560K J 1/16W	
R86			RK73HB1J472J	CHIP R 4.7K J 1/16W		R516			RK73GB2A472J	CHIP R 4.7K J 1/10W	
R87			RK73GB2A472J	CHIP R 4.7K J 1/10W		R518			RK73HB1J000J	CHIP R 0.0 J 1/16W	
R88,89			RK73HB1J474J	CHIP R 470K J 1/16W		R520			RK73HB1J332J	CHIP R 3.3K J 1/16W	
R300			RK73HB1J472J	CHIP R 4.7K J 1/16W		R521			RK73HB1J222J	CHIP R 2.2K J 1/16W	
R301			RK73HB1J273J	CHIP R 27K J 1/16W		R522			RK73HB1J272J	CHIP R 2.7K J 1/16W	
R302			RK73HB1J103J	CHIP R 10K J 1/16W		R523			RK73HB1J000J	CHIP R 0.0 J 1/16W	
R309,310			RK73GB2A220J	CHIP R 22 J 1/10W		R524			RK73HB1J103J	CHIP R 10K J 1/16W	
R311			RK73GB2A470J	CHIP R 47 J 1/10W		R525			RK73HB1J000J	CHIP R 0.0 J 1/16W	
R313			RK73HB1J101J	CHIP R 100 J 1/16W		R526			RK73HB1J474J	CHIP R 470K J 1/16W	
R315			RK73GB2A470J	CHIP R 47 J 1/10W		R527			RK73HB1J101J	CHIP R 100 J 1/16W	
R316			RK73HB1J000J	CHIP R 0.0 J 1/16W		R528			RK73HB1J224J	CHIP R 220K J 1/16W	
R317			RK73HB1J224J	CHIP R 220K J 1/16W	M1,K1,K2	R529			RK73HB1J000J	CHIP R 0.0 J 1/16W	
R317			RK73HB1J334J	CHIP R 330K J 1/16W	M	R530			RK73HB1J560J	CHIP R 56 J 1/16W	
R319,320			RK73HB1J103J	CHIP R 10K J 1/16W		R531			RK73HB1J391J	CHIP R 390 J 1/16W	
R321			RK73HB1J000J	CHIP R 0.0 J 1/16W		R533			RK73HB1J102J	CHIP R 1.0K J 1/16W	
R323			RK73HB1J273J	CHIP R 27K J 1/16W	M	R534			RK73HB1J391J	CHIP R 390 J 1/16W	
R323			RK73HB1J333J	CHIP R 33K J 1/16W	M1,K1,K2	R536			RK73HB1J562J	CHIP R 5.6K J 1/16W	
R324			RK73HB1J000J	CHIP R 0.0 J 1/16W		R537			RK73HB1J563J	CHIP R 56K J 1/16W	
R326			RK73HB1J223J	CHIP R 22K J 1/16W	M1,K1,K2	R538			RK73HB1J470J	CHIP R 47 J 1/16W	
R326			RK73HB1J473J	CHIP R 47K J 1/16W	M	R540,541			RK73HB1J823J	CHIP R 82K J 1/16W	
R328,329			RK73HB1J000J	CHIP R 0.0 J 1/16W		R542			RK73HB1J224J	CHIP R 220K J 1/16W	
R330,331			RK73HB1J104J	CHIP R 100K J 1/16W		R543			RK73HB1J684J	CHIP R 680K J 1/16W	
R333			RK73HB1J104J	CHIP R 100K J 1/16W		R545			RK73HB1J391J	CHIP R 390 J 1/16W	
R334			RK73GH2A560D	CHIP R 56 D 1/10W		R546			RK73HB1J823J	CHIP R 82K J 1/16W	
R336,337			RK73HB1J104J	CHIP R 100K J 1/16W		R547			RK73HB1J394J	CHIP R 390K J 1/16W	
R339			RK73GH2A101D	CHIP R 100 D 1/10W	M	R548			RK73HB1J154J	CHIP R 150K J 1/16W	
R339			RK73GH2A820D	CHIP R 82 D 1/10W	M1,K1,K2	R549			RK73HB1J270J	CHIP R 27 J 1/16W	
R340,341			RK73HB1J000J	CHIP R 0.0 J 1/16W		R550,551			RK73HB1J000J	CHIP R 0.0 J 1/16W	
R342			RK73HB1J104J	CHIP R 100K J 1/16W		R552			RK73HB1J105J	CHIP R 1.0M J 1/16W	
R343			RK73GH2A201D	CHIP R 200 D 1/10W		R557,558			RK73HB1J105J	CHIP R 1.0M J 1/16W	
R344			RK73HB1J000J	CHIP R 0.0 J 1/16W		R561			RK73HB1J000J	CHIP R 0.0 J 1/16W	
R345			RK73RB2H101J	CHIP R 100 J 1/2W		R563,564			RK73HB1J000J	CHIP R 0.0 J 1/16W	

K1: TK-8360H K K2: TK-8360H(U) K  
M: TK-8360 M M1: TK-8360H M

## PARTS LIST

## TX-RX UNIT (X57-8020-XX)

Ref. No.	Address	New parts	Parts No.	Description	Destination	Ref. No.	Address	New parts	Parts No.	Description	Destination
R565			RK73HB1J223J	CHIP R 22K J 1/16W		R772			RK73GB2A000J	CHIP R 0.0 J 1/10W	
R566			RK73HB1J221J	CHIP R 220 J 1/16W		R773			RK73HB1J000J	CHIP R 0.0 J 1/16W	
R567			RK73HB1J104J	CHIP R 100K J 1/16W		R774			RK73HB1J561J	CHIP R 560 J 1/16W	
R568			RK73HB1J564J	CHIP R 560K J 1/16W		R775			RK73HB1J000J	CHIP R 0.0 J 1/16W	
R569			RK73HB1J223J	CHIP R 22K J 1/16W		R776			RK73GB2A124J	CHIP R 120K J 1/10W	
R570			RK73HB1J823J	CHIP R 82K J 1/16W		R779,780			RK73HH1J473D	CHIP R 47K D 1/16W	
R571			RK73HB1J683J	CHIP R 68K J 1/16W		R781			RK73HB1J183J	CHIP R 18K J 1/16W	
R572			RK73HB1J000J	CHIP R 0.0 J 1/16W		R782			RK73HB1J104J	CHIP R 100K J 1/16W	
R573,574			RK73HB1J223J	CHIP R 22K J 1/16W		R785			RK73HB1J000J	CHIP R 0.0 J 1/16W	
R575			RK73HB1J000J	CHIP R 0.0 J 1/16W		R786			RK73HB1J473J	CHIP R 47K J 1/16W	
R576,577			RK73HB1J104J	CHIP R 100K J 1/16W		R787			RK73HB1J333J	CHIP R 33K J 1/16W	
R578			RK73FB2B000J	CHIP R 0.0 J 1/8W		R788			RK73HB1J000J	CHIP R 0.0 J 1/16W	
R579			RK73GB2A000J	CHIP R 0.0 J 1/10W		R789			RK73HB1J563J	CHIP R 56K J 1/16W	
R580			RK73HB1J104J	CHIP R 100K J 1/16W		R790			RK73HB1J000J	CHIP R 0.0 J 1/16W	
R581			RK73GB2A000J	CHIP R 0.0 J 1/10W		R791			RK73HB1J223J	CHIP R 22K J 1/16W	
R582			RK73HB1J471J	CHIP R 470 J 1/16W		R792			RK73HB1J561J	CHIP R 560 J 1/16W	
R583			RK73HB1J100J	CHIP R 10 J 1/16W		R793			RK73HB1J103J	CHIP R 10K J 1/16W	
R584			RK73HB1J471J	CHIP R 470 J 1/16W		R794,795			RK73HB1J102J	CHIP R 1.0K J 1/16W	
R586			RK73HB1J000J	CHIP R 0.0 J 1/16W		R799			RK73HB1J273J	CHIP R 27K J 1/16W	
R700			RK73HB1J223J	CHIP R 22K J 1/16W		R801			RK73HB1J562J	CHIP R 5.6K J 1/16W	
R701			RK73HB1J103J	CHIP R 10K J 1/16W		R802			RK73HB1J000J	CHIP R 0.0 J 1/16W	
R703			RK73HB1J000J	CHIP R 0.0 J 1/16W		R803			RK73HB1J563J	CHIP R 56K J 1/16W	
R707			RK73HB1J102J	CHIP R 1.0K J 1/16W		R804,805			RK73HB1J000J	CHIP R 0.0 J 1/16W	
R708			RK73HB1J101J	CHIP R 100 J 1/16W		R806,807			RK73HB1J104J	CHIP R 100K J 1/16W	
R709			RK73HB1J102J	CHIP R 1.0K J 1/16W		R809,810			RK73HB1J000J	CHIP R 0.0 J 1/16W	
R710,711			RK73HB1J000J	CHIP R 0.0 J 1/16W		R811			RK73HB1J104J	CHIP R 100K J 1/16W	
R713			RK73HB1J000J	CHIP R 0.0 J 1/16W		R813			RK73HB1J104J	CHIP R 100K J 1/16W	
R718			RK73HB1J000J	CHIP R 0.0 J 1/16W		R814			RK73HB1J101J	CHIP R 100 J 1/16W	
R721-723			RK73HB1J000J	CHIP R 0.0 J 1/16W		R815			RK73GB2A000J	CHIP R 0.0 J 1/10W	
R724			RK73GB2A000J	CHIP R 0.0 J 1/10W		R816			RK73HB1J104J	CHIP R 100K J 1/16W	
R725			RK73HB1J000J	CHIP R 0.0 J 1/16W		R817			RK73GB2A104J	CHIP R 100K J 1/10W	
R726			RK73GB2A000J	CHIP R 0.0 J 1/10W		R818			RK73HB1J104J	CHIP R 100K J 1/16W	
R728			RK73HB1J472J	CHIP R 4.7K J 1/16W		R819			RK73HB1J101J	CHIP R 100 J 1/16W	
R730			RK73HB1J681J	CHIP R 680 J 1/16W		R820			RK73HB1J000J	CHIP R 0.0 J 1/16W	
R733			RK73GB2A000J	CHIP R 0.0 J 1/10W		R823			RK73HB1J124J	CHIP R 120K J 1/16W	
R734			RK73HB1J102J	CHIP R 1.0K J 1/16W		R824			RK73HB1J000J	CHIP R 0.0 J 1/16W	
R735			RK73GB2A473J	CHIP R 47K J 1/10W		R825			RK73HB1J104J	CHIP R 100K J 1/16W	
R736			RK73HB1J821J	CHIP R 820 J 1/16W		R826			RK73HB1J101J	CHIP R 100 J 1/16W	
R737			RK73HB1J000J	CHIP R 0.0 J 1/16W		R827			RK73HB1J104J	CHIP R 100K J 1/16W	
R738			RK73GB2A221J	CHIP R 220 J 1/10W		R829			RK73HB1J101J	CHIP R 100 J 1/16W	
R739			RK73HB1J223J	CHIP R 22K J 1/16W		R830			RK73GB2A100J	CHIP R 10 J 1/10W	
R741			RK73HB1J223J	CHIP R 22K J 1/16W		R831			RK73HB1J473J	CHIP R 47K J 1/16W	
R742			RK73HB1J823J	CHIP R 82K J 1/16W		R832			RK73HB1J472J	CHIP R 4.7K J 1/16W	
R743			RK73HB1J561J	CHIP R 560 J 1/16W		R840			RK73HB1J473J	CHIP R 47K J 1/16W	
R744			RK73HB1J102J	CHIP R 1.0K J 1/16W		R841			RK73HB1J000J	CHIP R 0.0 J 1/16W	
R745,746			RK73HB1J000J	CHIP R 0.0 J 1/16W		R842			RK73HB1J103J	CHIP R 10K J 1/16W	
R747			RK73HB1J101J	CHIP R 100 J 1/16W		R843			RK73HB1J393J	CHIP R 39K J 1/16W	
R748			RK73HB1J123J	CHIP R 12K J 1/16W		R845			RK73GB2A000J	CHIP R 0.0 J 1/10W	
R749			RK73HB1J000J	CHIP R 0.0 J 1/16W		R846			RK73HB1J123J	CHIP R 12K J 1/16W	
R750			RK73HB1J105J	CHIP R 1.0M J 1/16W		R849			RK73HB1J682J	CHIP R 6.8K J 1/16W	
R751			RK73HB1J000J	CHIP R 0.0 J 1/16W		R850			RK73HB1J102J	CHIP R 1.0K J 1/16W	
R754			RK73HB1J123J	CHIP R 12K J 1/16W		R851			RK73HB1J223J	CHIP R 22K J 1/16W	
R755			RK73HB1J154J	CHIP R 150K J 1/16W		R852			RK73HB1J473J	CHIP R 47K J 1/16W	
R756			RK73HB1J103J	CHIP R 10K J 1/16W		R853			RK73HB1J332J	CHIP R 3.3K J 1/16W	
R757			RK73HB1J222J	CHIP R 2.2K J 1/16W		R854,855			RK73HB1J473J	CHIP R 47K J 1/16W	
R760,761			RK73GB2A000J	CHIP R 0.0 J 1/10W		R856			RK73HB1J222J	CHIP R 2.2K J 1/16W	
R762			RK73HB1J334J	CHIP R 330K J 1/16W		R857,858			RK73HB1J104J	CHIP R 100K J 1/16W	
R763			RK73HB1J154J	CHIP R 150K J 1/16W		R859			RK73HB1J105J	CHIP R 1.0M J 1/16W	
R765			RK73HB1J103J	CHIP R 10K J 1/16W		R860			RK73GB2A102J	CHIP R 1.0K J 1/10W	
R769			RK73HB1J000J	CHIP R 0.0 J 1/16W		R861			RK73HB1J153J	CHIP R 15K J 1/16W	

## PARTS LIST

TX-RX UNIT (X57-8020-XX)

Ref. No.	Address	New parts	Parts No.	Description	Desti-nation	Ref. No.	Address	New parts	Parts No.	Description	Desti-nation
R863			RK73GB2A472J	CHIP R 4.7K J 1/10W		D1			1SS389-F	DIODE	
R864			RK73HB1J123J	CHIP R 12K J 1/16W		D7			1SV325F	VARIABLE CAPACITANCE DIODE	
R866,867			RK73HB1J102J	CHIP R 1.0K J 1/16W		D9-15			1SV325F	VARIABLE CAPACITANCE DIODE	
R868			RK73HB1J000J	CHIP R 0.0 J 1/16W		D16			1SV278F	VARIABLE CAPACITANCE DIODE	
R869			RK73GH2A134D	CHIP R 130K D 1/10W		D17,18			HVC131	DIODE	
R870			RK73GH2A183D	CHIP R 18K D 1/10W		D300			UDZW5.1(B)	ZENER DIODE	
R871			RK73GB2A000J	CHIP R 0.0 J 1/10W		D301			1SS355	DIODE	
R872-874			RK73HB1J102J	CHIP R 1.0K J 1/16W		D302			HSC277	DIODE	
R875			RK73GB2A000J	CHIP R 0.0 J 1/10W		D303			L407CDB	DIODE (50V/1W)	M
R876-878			RK73HB1J102J	CHIP R 1.0K J 1/16W		D303,304			L407CDB	DIODE (50V/1W)	M1,K1,K2
R879			RK73HB1J000J	CHIP R 0.0 J 1/16W		D305,306			HSB88AS-E	DIODE	
R880			RK73HB1J154J	CHIP R 150K J 1/16W		D307	*		RKP350KV	DIODE	M1,K1,K2
R881			RK73HB1J000J	CHIP R 0.0 J 1/16W		D307,308	*		RKP350KV	DIODE	M
R883			RK73HB1J000J	CHIP R 0.0 J 1/16W		D309,310			UDZW3.3(B)	ZENER DIODE	
R885			RK73HB1J102J	CHIP R 1.0K J 1/16W		D311			L7091CER	DIODE	M1,K1,K2
R886			RK73HB1J000J	CHIP R 0.0 J 1/16W		D400			Z5W27V	SURGE ABSORBER	
R887			RK73HB1J102J	CHIP R 1.0K J 1/16W		D500,501			MC2858-T111	DIODE	
R888			RK73HB1J000J	CHIP R 0.0 J 1/16W		D502			HSB88AS-E	DIODE	
R889			RK73HB1J102J	CHIP R 1.0K J 1/16W		D503-507			1SV305F	VARIABLE CAPACITANCE DIODE	
R893,894			RK73HB1J000J	CHIP R 0.0 J 1/16W		D508			HVC369B	VARIABLE CAPACITANCE DIODE	
R895			RK73HB1J102J	CHIP R 1.0K J 1/16W		D700			DA2S101	DIODE	
R896			RK73HB1J000J	CHIP R 0.0 J 1/16W		D701-711			DA221	DIODE	
R897,898			RK73HB1J473J	CHIP R 47K J 1/16W		D712			MC2858-T111	DIODE	
R899-902			RK73HB1J000J	CHIP R 0.0 J 1/16W		D713			1SS372F	DIODE	
R905			RK73GB2A000J	CHIP R 0.0 J 1/10W		D715			UDZW18(B)	ZENER DIODE	
R906,907			RK73HB1J473J	CHIP R 47K J 1/16W		D716			DA2S101	DIODE	
R908,909			RK73HB1J472J	CHIP R 4.7K J 1/16W		IC1			TC75S51FE(F)	MOS-IC	
R910			RK73HB1J471J	CHIP R 470 J 1/16W		IC2			MB15E03SL-E1	MOS-IC	
R911			RK73HB1J152J	CHIP R 1.5K J 1/16W		IC3			BD7542FVM	MOS-IC	
R912			RK73GB2A102J	CHIP R 1.0K J 1/10W		IC300	2B		RA60H44521101	POWER MODULE	M1,K1,K2
R913			RK73HB1J473J	CHIP R 47K J 1/16W		IC300	2B		S-AU83AH	POWER MODULE	M
R914-917			RK73HB1J000J	CHIP R 0.0 J 1/16W		IC301			HA17358BFEL-E	MOS-IC	
R918			RK73HB1J223J	CHIP R 22K J 1/16W		IC400			TA4809BF	ANALOGUE IC	
R919			RK73HB1J473J	CHIP R 47K J 1/16W		IC401	*		XC6221B332N-G	MOS-IC	
R920			RK73HB1J472J	CHIP R 4.7K J 1/16W		IC402			TA7805F-NQ	MOS-IC	
R921			RK73HB1J473J	CHIP R 47K J 1/16W		IC403			BD4740G	MOS-IC	
R923			RK73HB1J472J	CHIP R 4.7K J 1/16W		IC404	*		XC6120N402N-G	MOS-IC	
R924,925			RK73HB1J473J	CHIP R 47K J 1/16W		IC500	*		UA31136L	MOS-IC	
R927,928			RK73HB1J473J	CHIP R 47K J 1/16W		IC501			HA17358BFEL-E	MOS-IC	
R929,930			RK73HB1J472J	CHIP R 4.7K J 1/16W		IC700			ADM202EARNZ	MOS-IC	
R931,932			RK73HB1J224J	CHIP R 220K J 1/16W		IC701			NJM2100V-ZB	MOS-IC	
R933,934			RK73HB1J823J	CHIP R 82K J 1/16W		IC702			CD686A03	MOS-IC	
R935,936			RK73HB1J222J	CHIP R 2.2K J 1/16W		IC703	*		XC6221B332N-G	MOS-IC	
R938			RK73HB1J391J	CHIP R 390 J 1/16W		IC704	*		F3650TDFBKEBA	MCU	
R940-942			RK73FB2B000J	CHIP R 0.0 J 1/8W		IC705			EX25512ATA00A	ROM IC	
R943			RK73HB1J104J	CHIP R 100K J 1/16W		IC706	1A		LA4600	BI-POLAR IC	
R944			RK73HB1J473J	CHIP R 47K J 1/16W		IC707			TC7S66FUF	MOS-IC	
R945			RK73HB1J103J	CHIP R 10K J 1/16W		IC708			TC4W53FU-F	MOS-IC	
R947			RK73HB1J103J	CHIP R 10K J 1/16W		IC709			NJM2746RB1-ZB	ANALOGUE IC	
R948			RK73HB1J684J	CHIP R 680K J 1/16W		IC710			TC7W53FK(F)	MOS-IC	
R949			RK73HB1J394J	CHIP R 390K J 1/16W		Q1			KTC4075E(Y,GR)	TRANSISTOR	
R950			RK73HB1J105J	CHIP R 1.0M J 1/16W		Q4			SSM3J05FU-F	FET	
R951			RK73HB1J332J	CHIP R 3.3K J 1/16W		Q5			2SK1830F	FET	
R952			RK73HB1J101J	CHIP R 100 J 1/16W		Q6			MCH3914(7)-H	FET	
R953			RK73HB1J103J	CHIP R 10K J 1/16W		Q7			2SJ347F	FET	
R954			RK73HB1J332J	CHIP R 3.3K J 1/16W		Q8			MCH3914(7)-H	FET	
R955			RK73HB1J472J	CHIP R 4.7K J 1/16W		Q10			KRX102U	TRANSISTOR	
R956,957			RK73HB1J223J	CHIP R 22K J 1/16W		Q11			KTC4075E(Y,GR)	TRANSISTOR	
R960			RK73HB1J000J	CHIP R 0.0 J 1/16W		Q12,13			2SC5108(YF)	TRANSISTOR	
R962			RK73HB1J823J	CHIP R 82K J 1/16W		Q300			RD00HVS1-T113	FET	

K1: TK-8360H K K2: TK-8360H(U) K  
M: TK-8360 M M1: TK-8360H M

If a part reference number is listed in a shaded box, that part does not come with the PCB.

## PARTS LIST

## TX-RX UNIT (X57-8020-XX)

Ref. No.	Address	New parts	Parts No.	Description	Destination	Ref. No.	Address	New parts	Parts No.	Description	Destination
Q400,401			RT1N141U-T111	TRANSISTOR							
Q402,403			2SB1694	TRANSISTOR							
Q404,405			SSM3J05FU-F	FET							
Q406			KTC4075E(Y,GR)	TRANSISTOR							
Q407			2SJ645	FET							
Q500			2SC5108(Y)F	TRANSISTOR							
Q502			RT1P441U-T111	TRANSISTOR							
Q503			RT1N441U-T111	TRANSISTOR							
Q504			2SC5108(Y)F	TRANSISTOR							
Q505			2SC2412K	TRANSISTOR							
Q506			KTC4075E(Y,GR)	TRANSISTOR							
Q507			3SK318	FET							
Q508			RT1N141U-T111	TRANSISTOR							
Q511			3SK318	FET							
Q700			2SC4116(Y)F	TRANSISTOR							
Q702			2SJ645	FET							
Q703			2SC4919-S	TRANSISTOR							
Q704			2SK1830F	FET							
Q705			KTC4075E(Y,GR)	TRANSISTOR							
Q708			KTC4075E(Y,GR)	TRANSISTOR							
Q709			SSM3J05FU-F	FET							
Q710			KTC4075E(Y,GR)	TRANSISTOR							
Q712			SSM3J05FU-F	FET							
Q713			2SK1824-A	FET							
Q714			RT1N440M-T111	TRANSISTOR							
Q715			DTC114YEB	TRANSISTOR							
Q716			KTC4075E(Y,GR)	TRANSISTOR							
Q717			RT1N441U-T111	TRANSISTOR							
Q718,719			SSM3K05FU	FET							
Q720			RT1N141U-T111	TRANSISTOR							
TH300-302			B57331V2104J	THERMISTOR (100K)							
TH501		*	NCP18WD683JOS	THERMISTOR (68K)							

## EXPLODED VIEW

- A : N35-2604-43
- B : N67-3008-48
- C : N87-2608-48

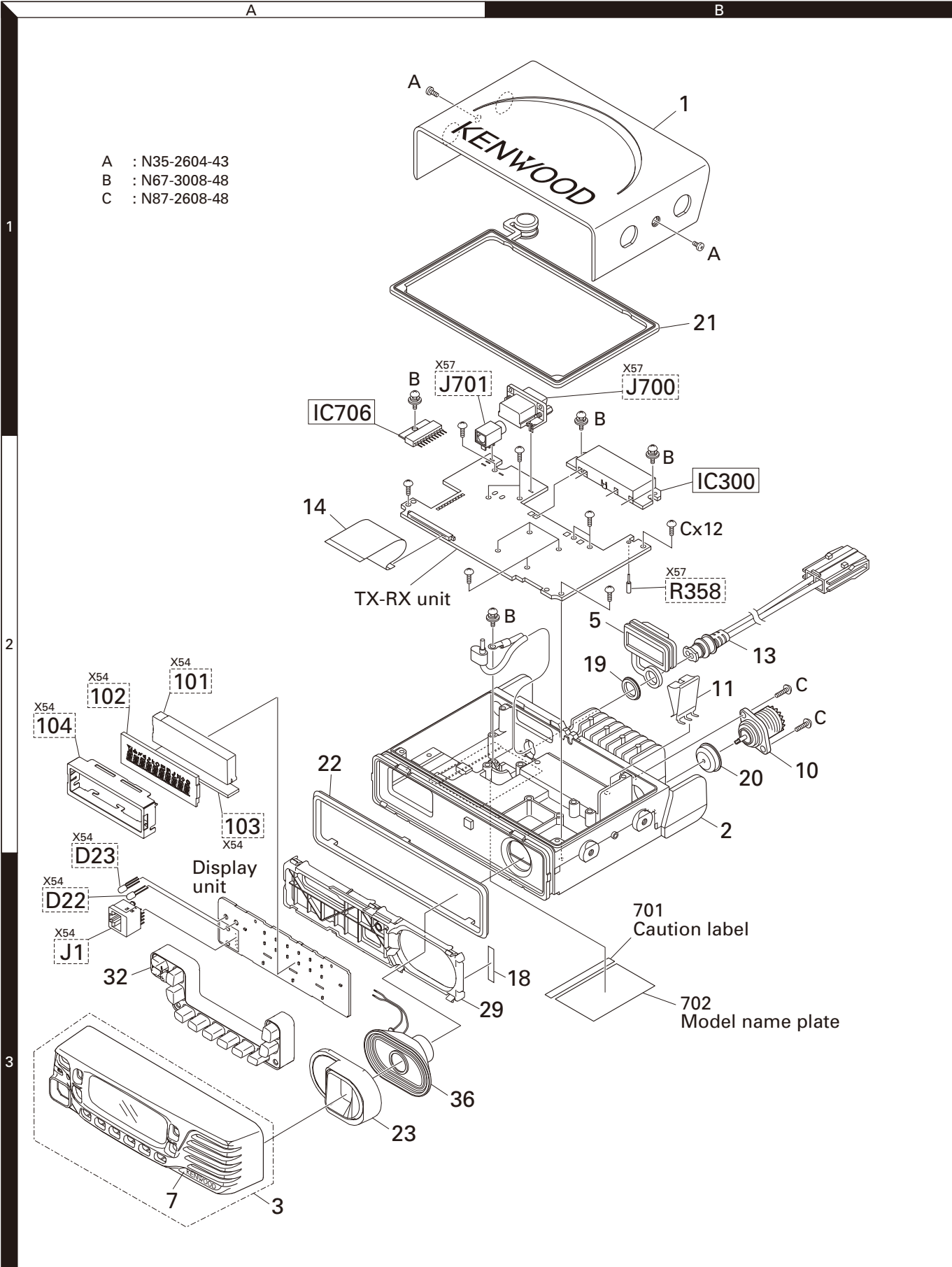

Parts with the exploded numbers larger than 700 are not supplied.  
 If a part reference number is listed in a box on the exploded view of the PCB, that part does not come with the PCB.  
 These parts must be ordered separately.

## PACKING

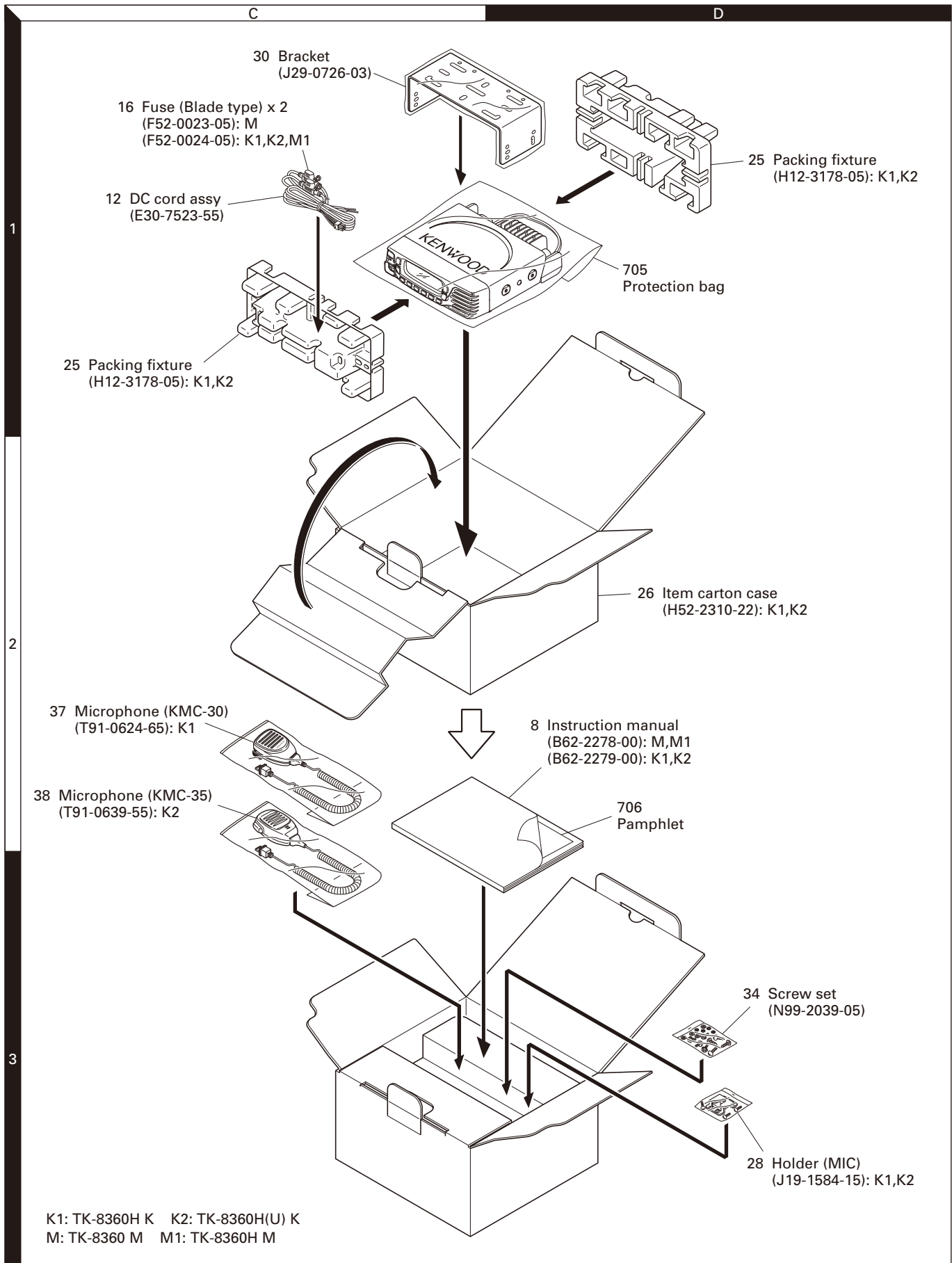

Parts with the exploded numbers larger than 700 are not supplied.



## ADJUSTMENT

### Controls

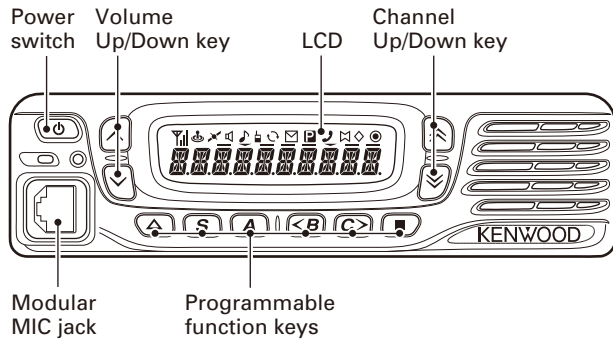

### Panel Test Mode

#### ■ Test mode operation features

This transceiver has a test mode. **To enter test mode, press and hold the [A] key while turning the transceiver power ON. Before the transceiver enters test mode, the frequency version information appears on the LCD momentarily.** Test mode can be inhibited by programming. To exit test mode, turn the transceiver power OFF. The following functions are available in test mode.

#### ■ Key operation

Key	“-” not appears	
	Function	Display
[S]	Shifts to Panel tuning mode	-
[A]	Function on	“-” appears
[<B]	MSK 1200bps and 2400bps	2400bps: ☒ icon appears
[C>]	Test signaling CH up	Signaling No.
[^]/[v]	Test frequency CH up/down	Channel No.
[^]/[v]	Volume up/down	-
[Δ]	Squelch on/off	🔊
☐	Narrow/Wide	Narrow: “N”, Wide: “W”
<b>Microphone key</b>		
[PTT]	Transmit	-
[0] to [9] and [#], [*]	Use as the DTMF keypad. If a key is pressed during transmission, the DTMF corresponding to the key that was presses is sent.	-

Key	“-” appears	
	Function	Display
[S]	High power / Low power	Low: “-” icon appears
[A]	Function off	-
[<B]	Compander on/off	On: 🎧 icon appears
[C>]	Beat shift on/off	On: ⬠ icon appears
[^]/[v]	Function off	-
[^]/[v]	Function off	-
[Δ]	Squelch level 0	On: 📢 icon appears
☐	LCD all lights	LCD all point appears
<b>Microphone key</b>		
[PTT]	Transmit	-
[0] to [9] and [#], [*]	Function off	-

#### • LED indicator

- Red LED Lights during transmission.
- Green LED Lights when there is carrier.

#### • LCD display in panel test mode

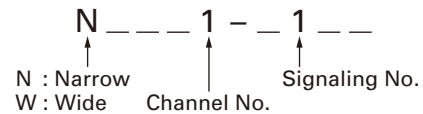

#### ■ Frequency and Signaling

The transceiver has been adjusted for the frequencies shown in the following table. When required, readjust them following the adjustment procedure to obtain the frequencies you want in actual operation.

#### • Frequency (MHz)

Channel	RX Frequency	TX Frequency
1	485.05000	485.10000
2	450.05000	450.10000
3	519.95000	519.90000
4	485.00000	485.00000
5	485.20000	485.20000
6	485.40000	485.40000
7~16	-	-

## ADJUSTMENT

### • Signaling

Signaling No.	RX (Decode)	TX (Encode)
1	None	None
2	None	20Hz Square Wave
4	QT: 67.0Hz	QT: 67.0Hz
5	QT: 151.4Hz	QT: 151.4Hz
6	QT: 210.7Hz	QT: 210.7Hz
7	QT: 254.1Hz	QT: 254.1Hz
8	DQT: D023N	DQT: D023N
9	DQT: D754I	DQT: D754I
10	DTMF (CODE: 159D)	DTMF (CODE: 159D)
11	None	DTMF (CODE: 9)
12	None	MSK (1010..)
13	FleetSync: 100-1000	Fleet Sync: 100-1000
14	None	Single Tone (1000Hz)
15	2-tone (A: 304.7Hz, B: 3106.0Hz)	2-tone (A: 304.7Hz, B: 3106.0Hz)
16	None	Single Tone (1477Hz)
17	Single Tone (979.9Hz)	Single Tone (979.9Hz)
18	None	MSK PN9

### Panel Tuning Mode

#### ■ Preparations for tuning the transceiver

Before attempting to tune the transceiver, connect the unit to a suitable power supply.

Whenever the transmitter is turned, the transceiver must be connected to a suitable dummy load (i.e. power meter).

The speaker output connector must be terminated with a 4Ω dummy load and connected to an AC voltmeter and an audio distortion meter or a SINAD measurement meter at all times during tuning.

#### ■ Transceiver tuning

##### (To place transceiver in tuning mode)

Press [S] key, now in tuning mode. Use [<B] key to write tuning data through tuning modes, and [↗]/[↘] to adjust tuning requirements (1 to 70/256/1024/4096 appears on LCD).

Use [C>] key to select the adjustment item through tuning modes. Use [A] key to adjust 5 reference level adjustments, and use [■] key to switch between Wide/Narrow.

Channel appears on LCD. Set channel according to tuning requirements.

#### • LCD display in panel tuning mode

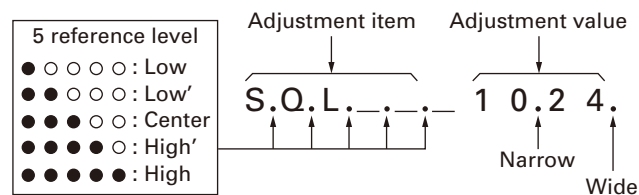

### ■ Key operation

Key	Function	
	Push	Hold (1 second)
[S]	End of panel tuning mode	-
[A]	To enter 5 reference level adjustments	-
[<B]	Writes the adjustment value	-
[C>]	Go to next adjustment item	Back to last adjustment item
[↗]/[↘]	Adjustment value up/down	Continuation up/down
[^]/[v]	Volume level up/down	Continuation up/down
[Δ]	Squelch on/off	-
[■]	Selects Narrow, Wide	-

### ■ 5 reference level adjustments frequency (MHz)

TEST CH	RX	TX
Low	450.05000	450.10000
Low'	467.55000	467.50000
Center	485.05000	485.10000
High'	502.55000	502.50000
High	519.95000	519.90000

### ■ Adjustment item and Display

(\*\*\*1: 1~1024, \*\*\*4: 1~4048,  
Only Frequency: 1~256, Only DQT: 1~70)

Order	Adjustment item	Display
1	RX Assist	RXASS ***1
2	TX Assist	TXASS ***1
3	Frequency	FREQ **2
4	High Power	HPOW ***1
5	Mid Power	MPOW ***1
6	Low Power	LPOW ***1
7	DQT Balance	BAL *7
8	Max Deviation	DEV ***4
9	DQT Deviation	DQT ***4
10	QT Deviation	QT ***4
11	DTMF Deviation	DTMF ***4
12	MSK Deviation	MSK ***4
13	Sensitivity (Semi-auto)	SENS1 ***1
14	Sensitivity (Not used)	SENS2 ***1
15	Squelch Open (5)	SQL ***1
16	Squelch tight	SQLT ***1
17	Low RSSI	LRSSI ***1
18	High RSSI	HRSSI ***1

# ADJUSTMENT

## Flow chart

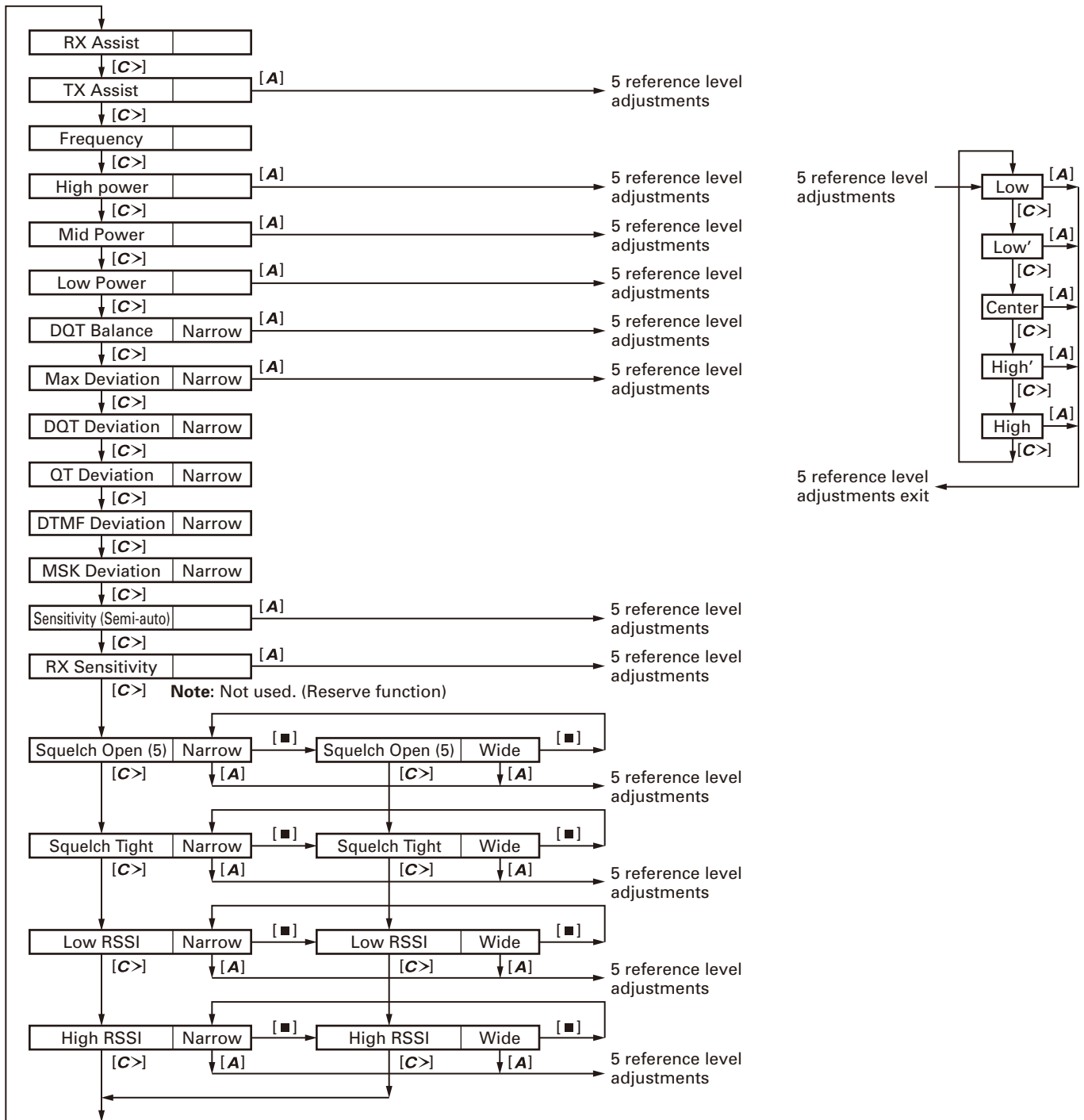

## ADJUSTMENT

### Test Equipment Required for Alignment

Test Equipment	Major Specifications	
1. Standard Signal Generator (SSG)	Frequency Range Modulation Output	400 to 520MHz Frequency modulation and external modulation -127dBm/0.1μV to greater than -7dBm/100mV
2. Power Meter	Input Impedance Operation Frequency Measurement Range	50Ω 400 to 520MHz or more Vicinity of 100W
3. Deviation Meter	Frequency Range	400 to 520MHz
4. Digital Volt Meter (DVM)	Measuring Range Input Impedance	1 to 20V DC High input impedance for minimum circuit loading
5. Oscilloscope		DC through 30MHz
6. High Sensitivity Frequency Counter	Frequency Range Frequency Stability	10Hz to 1000MHz 0.2ppm or less
7. Ammeter		20A or more
8. AF Volt Meter (AF VTVM)	Frequency Range Voltage Range	50Hz to 10kHz 1mV to 3V
9. Audio Generator (AG)	Frequency Range Output	20Hz to 20kHz or more 0 to 1V
10. Distortion Meter	Capability Input Level	3% or less at 1kHz 50mV to 10Vrms
11. 4Ω Dummy Load		Approx. 4Ω, 10W or more
12. Regulated Power Supply		13.6V, approx. 20A (adjustable from 9 to 17V) Useful if ammeter equipped
13. Spectrum Analyzer	Center Frequency	50kHz to 600MHz
14. Tracking Generator	Output Voltage	100mV or more

### Test cable for microphone input (E30-3360-28)

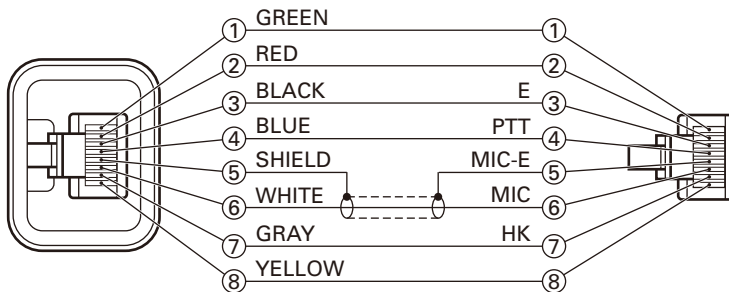

### MIC connector (Front panel view)

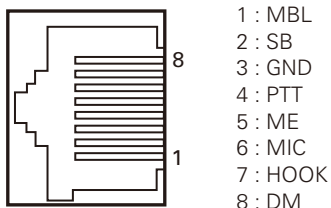

### Tuning cable (E30-3383-05)

Adapter cable (E30-3383-05) is required for injecting an audio if PC tuning is used.  
See "PC Mode" section for the connection.

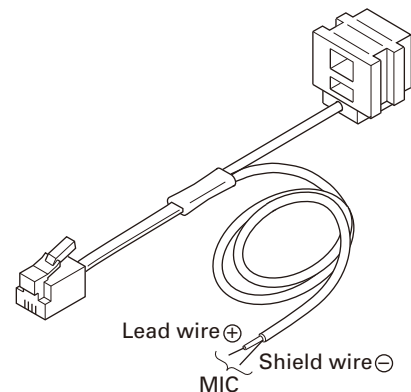

# ADJUSTMENT

## Common Section

Item	Condition		Measurement			Adjustment			Specifications / Remarks
	Panel tuning mode	PC test mode	Test-equipment	Unit	Terminal	Unit	Parts	Method	
1. Setting	1) Power supply voltage DC power supply terminal: 13.6V 2) SSG standard modulation [Wide] MOD: 1kHz, DEV: 3kHz [Narrow] MOD: 1kHz, DEV: 1.5kHz								
2. Receive Assist Voltage (Automatic)	1) Adj item: [RXASS] Adjust: [****] 2) TEST CH: Low, Low', Center, High', High (5 points) 3) Press [ <b>&lt;B</b> ] key to store the adjustment value.	1) (Auto tuning)*	Power meter				FPU	"Voltage Level" indicator on PC window shows VCO lock voltage. Change the adjustment value to get VCO lock voltage within the limit of the specified voltage.  <b>Note:</b> Confirm the VCO lock voltage approximately 3 seconds after the adjustment value is changed.	2.5V±0.2V
3. Transmit Assist Voltage (Automatic)	1) Adj item: [TXASS] Adjust: [****] 2) TEST CH: Low, Low', Center, High', High (5 points) 3) PTT: ON 4) Press [ <b>&lt;B</b> ] key to store the adjustment value.	1) (Auto tuning)* 2) Transmit							
4. VCO Lock Voltage Check	1) Adj item: [RXASS] Adjust: [****] 2) TEST CH: Low, Low', Center, High', High (5 points)  • RX  • TX	1) TEST CH: Low, Low', Center, High', High (5 points)	Power meter DVM	TX-RX	LV			Check	2.5V±0.2V
	3) Adj item: [TXASS] Adjust: [****] 4) TEST CH: Low, Low', Center, High', High (5 points) 5) Transmit	2) TEST CH: Low, Low', Center, High', High (5 points) 3) Transmit							

\*: At test mode, click [Tune Assist Voltage] button in test mode dialog box, then start automatic adjustment of Receive/Transmit assist voltage.

## Transmitter Section

Item	Condition		Measurement			Adjustment			Specifications / Remarks
	Panel tuning mode	PC test mode	Test-equipment	Unit	Terminal	Unit	Parts	Method	
1. Frequency	1) Adj item: [FREQ] Adjust: [***] 2) PTT: ON 3) Press [ <b>&lt;B</b> ] key to store the adjustment value.	1) TEST CH: TX center 2) Transmit	Frequency counter		ANT		[Panel tuning mode] [↵],[⏏]	Adjust to center frequency	Within ±100Hz
2. High Transmit Power	1) Adj item: [HPOW] Adjust: [****] 2) TEST CH: Low, Low', Center, High', High (5 points) 3) PTT: ON 4) Press [ <b>&lt;B</b> ] key to store the adjustment value.	1) TEST CH: Low, Low', Center, High', High (5 points) 2) Transmit	Power meter Ammeter				[PC test mode] FPU	25W	±1.0W 8.0A or less
• TK-8360  • TK-8360H/ 8360H(U)								45W	±2.0W 14.0A or less

## ADJUSTMENT

Item	Condition		Measurement			Adjustment			Specifications / Remarks
	Panel tuning mode	PC test mode	Test-equipment	Unit	Terminal	Unit	Parts	Method	
3. Mid Transmit Power  TK-8360H/ 8360H(U) only	1) Adj item: [MPOW] Adjust: [****] 2) TEST CH: Low, Low', Center, High', High (5 points) 3) PTT: ON 4) Press [ <b>&lt;B</b> ] key to store the adjust- ment value.	1) TEST CH: Low, Low', Center, High', High (5 points) 2) Transmit	Power meter Ammeter		ANT		[Panel tuning mode] [↵],[↶]  [PC test mode] FPU	25W	±1.0W 8.0A or less
4. Low Transmit Power	1) Adj item: [LPOW] Adjust: [****] 2) TEST CH: Low, Low', Center, High', High (5 points) 3) PTT: ON 4) Press [ <b>&lt;B</b> ] key to store the adjust- ment value.	1) TEST CH: Low, Low', Center, High', High (5 points) 2) Transmit						5W	±0.5W 4.0A or less
5. DQT Balance (Narrow)	1) Adj item: [BAL] Adjust: [**] 2) TEST CH: Low, Low', Center, High', High (5 points) 3) Deviation meter filter LPF: 3kHz HPF: OFF 4) PTT: ON Output 20Hz 5) Press [■] key during PTT ON. Output 1kHz 6) Press [ <b>&lt;B</b> ] key to store the adjust- ment value.	1) TEST CH: Low, Low', Center, High', High (5 points) 2) Deviation meter filter LPF: 3kHz HPF: OFF 3) Transmit	Deviation meter		ANT			The Deviation of 20Hz frequency is fixed. (FL=30, FLC=35, FC=40, FCH=45, FH=50) Change the 1kHz adjustment value to become the same deviation of 20Hz within the specified range.	±0.4dB
6. Maximum Deviation (Narrow)	1) Adj item: [DEV] Adjust: [****] 2) TEST CH: Low, Low', Center, High', High (5 points) 3) Deviation meter filter LPF: 15kHz HPF: OFF 4) PTT: ON 5) Press [ <b>&lt;B</b> ] key to store the adjust- ment value.	1) TEST CH: Low, Low', Center, High', High (5 points) 2) Deviation meter filter LPF: 15kHz HPF: OFF 3) Transmit	Deviation meter Oscillo- scope AG AF VTVM		ANT			2.2kHz (According to the large +, -)	±0.05kHz  <b>Note:</b> FPU auto input 1kHz/50mV
7. MIC Sensitivity Check	1) Adj item: [DEV] Adjust: [****] 2) TEST CH: Center 3) Deviation meter filter LPF: 15kHz HPF: OFF AG: 1kHz/5mV 4) PTT: ON	1) TEST CH: Center 2) Deviation meter filter LPF: 15kHz HPF: OFF AG: 1kHz/5mV 3) Transmit			ANT MIC			Check	1.1kHz~1.8kHz

## ADJUSTMENT

Item	Condition		Measurement			Adjustment			Specifications / Remarks
	Panel tuning mode	PC test mode	Test-equipment	Unit	Terminal	Unit	Parts	Method	
8. DQT Deviation (Narrow)	1) Adj item: [DOT] Adjust: [****] 2) TEST CH: Center 3) Deviation meter filter LPF: 3kHz HPF: OFF 4) PTT: ON 5) Press [ <b>&lt;B</b> ] key to store the adjustment value.	1) TEST CH: Center 2) Deviation meter filter LPF: 3kHz HPF: OFF 3) Transmit	Deviation meter Oscilloscope AG AF VTVM		ANT		[Panel tuning mode] [ <b>↶</b> ],[ <b>↷</b> ]  [PC test mode] FPU	0.35kHz	±0.05kHz
9. QT Deviation (Narrow)	1) Adj item: [QT] Adjust: [****] 2) TEST CH: Center 3) Deviation meter filter LPF: 3kHz HPF: OFF 4) PTT: ON 5) Press [ <b>&lt;B</b> ] key to store the adjustment value.	1) TEST CH: Center 2) Deviation meter filter LPF: 3kHz HPF: OFF 3) Transmit						0.35kHz	±0.05kHz
10. DTMF Deviation (Narrow)	1) Adj item: [DTMF] Adjust: [****] 2) TEST CH: Center 3) Deviation meter filter LPF: 15kHz HPF: OFF 4) PTT: ON 5) Press [ <b>&lt;B</b> ] key to store the adjustment value.	1) TEST CH: Center 2) Deviation meter filter LPF: 15kHz HPF: OFF 3) Transmit						1.5kHz	±0.05kHz
11. MSK Deviation (Narrow)	1) Adj item: [MSK] Adjust: [****] 2) TEST CH: Center 3) Deviation meter filter LPF: 15kHz HPF: OFF 4) PTT: ON 5) Press [ <b>&lt;B</b> ] key to store the adjustment value.	1) TEST CH: Center 2) Deviation meter filter LPF: 15kHz HPF: OFF 3) Transmit						1.5kHz	±0.05kHz

## ADJUSTMENT

## Receiver Section

Item	Condition		Measurement			Adjustment			Specifications / Remarks
	Panel tuning mode	PC test mode	Test-equipment	Unit	Terminal	Unit	Parts	Method	
1. Sensitivity (Semiauto-matic)	1) Adj item: [SENS1] Adjust: [****] 2) TEST CH: Low, Low', Center, High', High (5 points) 3) SSG output : -90dBm (7.08μV)	1) TEST CH: Low, Low', Center, High', High (5 points) 2) SSG output : -90dBm (7.08μV)	SSG Oscillo-scope AF VTVM Distortion meter		ANT Ext.SP			[Panel tuning mode] After input signal from SSG, press [ <b>&lt;B</b> ] key to store the adjustment value.  [PC test mode] After input signal from SSG, press [Apply] button to store the adjustment value.	
(Manual)	4) Adj item: [SENS2]  <b>Note:</b> Adj item [SENS2] is not used. If you mistakenly adjust "SENS2", readjust "SENS1" again.								
2. Open Squelch (5) (Narrow)	1) Adj item: [SQL] Adjust: [****] 2) TEST CH: Low, Low', Center, High', High (5 points) 3) SSG output Low, Low', Center : -120dBm (0.22μV) High', High : -121dBm (0.20μV)	1) TEST CH: Low, Low', Center, High', High (5 points) 2) SSG output Low, Low', Center : -120dBm (0.22μV) High', High : -121dBm (0.20μV)							Squelch open
(Wide)	1) Adj item: [SQL] Adjust: [****] 2) TEST CH: Low, Low', Center, High', High (5 points) 3) SSG output Low, Low', Center : -120dBm (0.22μV) High', High : -121dBm (0.20μV)	1) TEST CH: Low, Low', Center, High', High (5 points) 2) SSG output Low, Low', Center : -120dBm (0.22μV) High', High : -121dBm (0.20μV)							
3. Tight Squelch (Narrow)	1) Adj item: [SQLT] Adjust: [****] 2) TEST CH: Low, Low', Center, High', High (5 points) 3) SSG output Low, Low', Center : -115dBm (0.40μV) High', High : -116dBm (0.35μV)	1) TEST CH: Low, Low', Center, High', High (5 points) 2) SSG output Low, Low', Center : -115dBm (0.40μV) High', High : -116dBm (0.35μV)							
(Wide)	1) Adj item: [SQLT] Adjust: [****] 2) TEST CH: Low, Low', Center, High', High (5 points) 3) SSG output Low, Low', Center : -115dBm (0.40μV) High', High : -116dBm (0.35μV)	1) TEST CH: Low, Low', Center, High', High (5 points) 2) SSG output Low, Low', Center : -115dBm (0.40μV) High', High : -116dBm (0.35μV)							



# ADJUSTMENT

Item	Condition		Measurement			Adjustment			Specifications / Remarks
	Panel tuning mode	PC test mode	Test-equipment	Unit	Terminal	Unit	Parts	Method	
4. Low RSSI (Narrow)	1) Adj item: [LRSSI] Adjust: [****] 2) TEST CH: Low, Low', Center, High', High (5 points) 3) SSG output : -120dBm (0.22μV)	1) TEST CH: Low, Low', Center, High', High (5 points) 2) SSG output : -120dBm (0.22μV)	SSG Oscillo- scope AF VTVM Distortion meter		ANT Ext.SP			[Panel tuning mode] After input signal from SSG, press [<B>] key to store the adjustment value.  [PC test mode] After input signal from SSG, press [Apply] button to store the adjust- ment value.	
	(Wide)	1) Adj item: [LRSSI] Adjust: [****] 2) TEST CH: Low, Low', Center, High', High (5 points) 3) SSG output : -120dBm (0.22μV)							1) TEST CH: Low, Low', Center, High', High (5 points) 2) SSG output : -120dBm (0.22μV)
5. High RSSI (Narrow)	1) Adj item: [HRSSI] Adjust: [****] 2) TEST CH: Low, Low', Center, High', High (5 points) 3) SSG output : -70dBm (70.8μV)	1) TEST CH: Low, Low', Center, High', High (5 points) 2) SSG output : -70dBm (70.8μV)							
	(Wide)	1) Adj item: [HRSSI] Adjust: [****] 2) TEST CH: Low, Low', Center, High', High (5 points) 3) SSG output : -70dBm (70.8μV)							1) TEST CH: Low, Low', Center, High', High (5 points) 2) SSG output : -70dBm (70.8μV)

## Adjustment Points

### ■ Component side

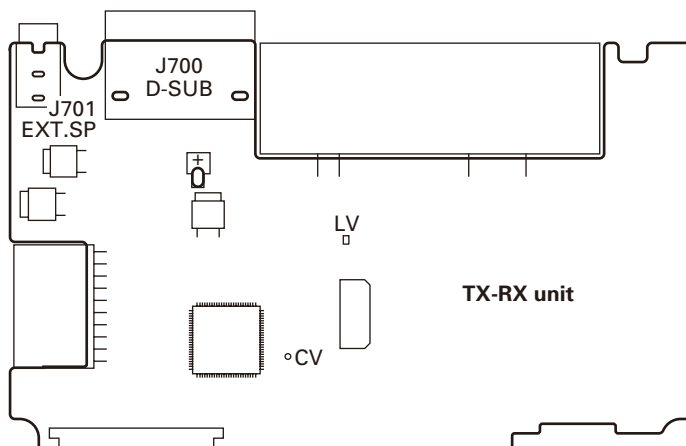

### ■ Foil side

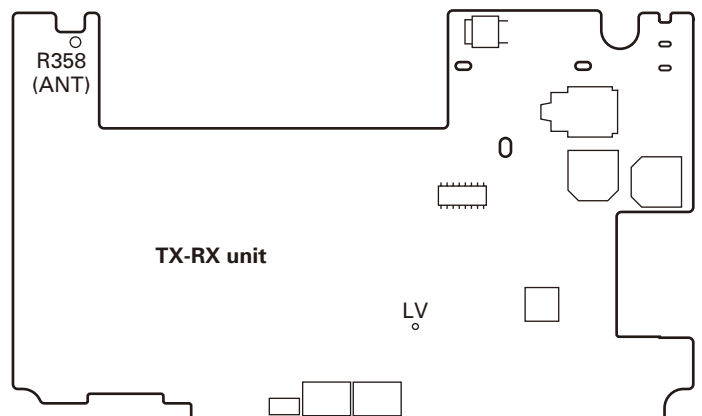

# TERMINAL FUNCTION

## Display unit (X54-3740-20)

Pin No.	Name	I/O	Function
<b>CN1 (to TX-RX unit CN701)</b>			
1	POWER	O	Detection output of power switch
2	MKEY	I/O	MIC data detection
3	PTT/TXD	I/O	PTT/PC serial data
4	HOOK/RXD	I/O	HOOK/PC serial data
5	ME	-	MIC ground
6	MIC	O	MIC signal output
7	GND	-	Ground
8	GND	-	Ground
9	LCDDO	O	LCD data output
10	LCCL	I	LCD clock input
11	LCCE	I	LCD enable input
12	LCDDI	I	LCD data input
13	5C	I	5V DC power supply
14	GND	-	Ground
15	GND	-	Ground
16	EMG	O	Emergency key detection
17	GND	-	Ground
18	NC	-	No connection
19	GND	-	Ground
20	BLED	I	Blue LED control signal input
21	GLED	I	Green LED control signal input
22	RLED	I	Red LED control signal input
23	MBL	I	MIC backlight control signal input
24	BLC	I	LCD backlight control signal input
25	SP-	I	Speaker input -
26	SP-	I	Speaker input -
27	SP+	I	Speaker input +
28	SP+	I	Speaker input +
29	SB	I	Battery voltage DC supply
30	SB	I	Battery voltage DC supply
<b>J1 (MIC jack)</b>			
1	MBL	O	MIC backlight control
2	SB	O	Battery voltage DC supply
3	GND	-	Ground
4	PTT	I/O	PTT/ PC serial data from radio
5	ME	-	MIC ground
6	MIC	I	MIC signal input
7	HOOK	I	HOOK/ PC serial data to radio
8	DM	I/O	MIC data detection

## TX-RX unit (X57-8020-XX)

Pin No.	Name	I/O	Function
<b>CN700 (Board to Board)</b>			
1	OPT1	I/O	VGS busy signal input (VGS-1) Scrambler code select 1 (Scrambler board)
2	OPT3	I/O	VGS playback signal input (VGS-1) Scrambler code select 2 (Scrambler board)
3	SI	I	Serial data input (VGS-1)
4	SO	I/O	Serial data output (VGS-1) PTT input (Scrambler board)
5	CK	O	Serial clock output (VGS-1)
6	OPT4	O	VGS enable output (VGS-1) Echo PTT output (Scrambler board)
7	USEL	-	Ground
8	OPT5	O	VGS reset signal output (VGS-1) Scrambler code select 8 (Scrambler board)
9	GND	-	Ground
10	GND	-	Ground
11	AI	I	VGS audio input (VGS-1)
12	AO	O	VGS audio output (VGS-1)
13	GND	-	Ground
14	5C	O	5V DC power supply (VGS-1)
15	STON	I	Side tone input (VGS-1)
16	DTI	I	Data signal input (VGS-1)
17	TCTL	-	No connection
18	NC	-	No connection
19	AUDIHI	-	No connection
20	OPT2	O	Scrambler Clear/Code select (Scrambler board)
21	TXO	O	MIC signal output (Scrambler board)
22	RXEO	O	Audio signal output (Scrambler board)
23	RXEI	I	Audio signal input (Scrambler board)
24	TXI	I	MIC signal input (Scrambler board)
25	OPT6	O	Scrambler code select 4 (Scrambler board)
26	9C	O	9V DC power supply (Scrambler board)
<b>CN701 (to Display unit CN1)</b>			
1	SB	O	Battery voltage DC supply
2	SB	O	Battery voltage DC supply
3	SP+	O	Speaker output +
4	SP+	O	Speaker output +
5	SP-	O	Speaker output -
6	SP-	O	Speaker output -
7	BLC	O	LCD backlight control signal output
8	MBL	O	MIC backlight control signal output
9	RLED	O	Red LED control signal output

## TERMINAL FUNCTION

Pin No.	Name	I/O	Function
10	GLED	O	Green LED control signal output
11	BLED	O	Blue LED control signal output
12	GND	-	Ground
13	NC	-	No connection
14	GND	-	Ground
15	EMG	I	Emergency key detection
16	GND	-	Ground
17	GND	-	Ground
18	5C	O	5V DC power supply
19	LCDDI	O	LCD data output
20	LCCE	O	LCD enable output
21	LCCL	O	LCD clock output
22	LCDDO	I	LCD data input
23	GND	-	Ground
24	GND	-	Ground
25	MIC	I	MIC signal input
26	ME	-	MIC ground
27	HOOK/RXD	I/O	HOOK/PC serial data
28	PTT/TXD	I/O	PTT/PC serial data
29	MKEY	I/O	MIC data detection
30	POWER	I	Detection input of power switch
<b>J700 (ACC 15-pin)</b>			
1	SB	O	Battery voltage DC supply, DC 13.6V±15%, 1.0A max
2	IGN	I	Ignition sense input, 16.0V max
3	PA	O	Speaker output
4	DETO	O	FM detector output, 500mVp-p
5	DATAI	I	External transmit signal input, 200±50mVp-p
6	FNC1	I/O	Programmable I/O (programmed by FPU), 1.0mA max
7	FNC2	I/O	Programmable I/O (programmed by FPU), 1.0mA max
8	FNC3	I/O	Programmable I/O (programmed by FPU), 1.0mA max
9	FNC4	I/O	Programmable I/O (programmed by FPU), 1.0mA max
10	FNC5	I/O	Programmable I/O (programmed by FPU), 1.0mA max
11	FNC6	I/O	Programmable I/O (programmed by FPU), 1.0mA max
12	5C	O	5V DC power supply, 100mA max
13	HR1	O	Horn alert signal output, 16.0V/2.0A max
14	HR2	O	Horn alert signal output, 16.0V/2.0A max
15	GND	-	Ground

## Function Port Assignment

	Scrambler	
	Name	I/O
FNC1	-	-
FNC2	-	-
FNC3	None	O
FNC4	Scrambler	O
FNC5	Scrambler code 1(1)	O
FNC6	Scrambler code 2(2)	O
FNC7	Scrambler code 3(4)	O
FNC8	Scrambler code 4(8)	O
GPS (NMEA)		
	Name	I/O
FNC1	None	O
FNC2	GPS (NMEA input)	I
FNC3	-	-
FNC4	-	-
FNC5	-	-
FNC6	-	-
FNC7	-	-
FNC8	-	-

# TK-8360/8360H/8360H(U) PC BOARD

**DISPLAY UNIT (X54-3740-20) Component side view (J79-0297-09)**

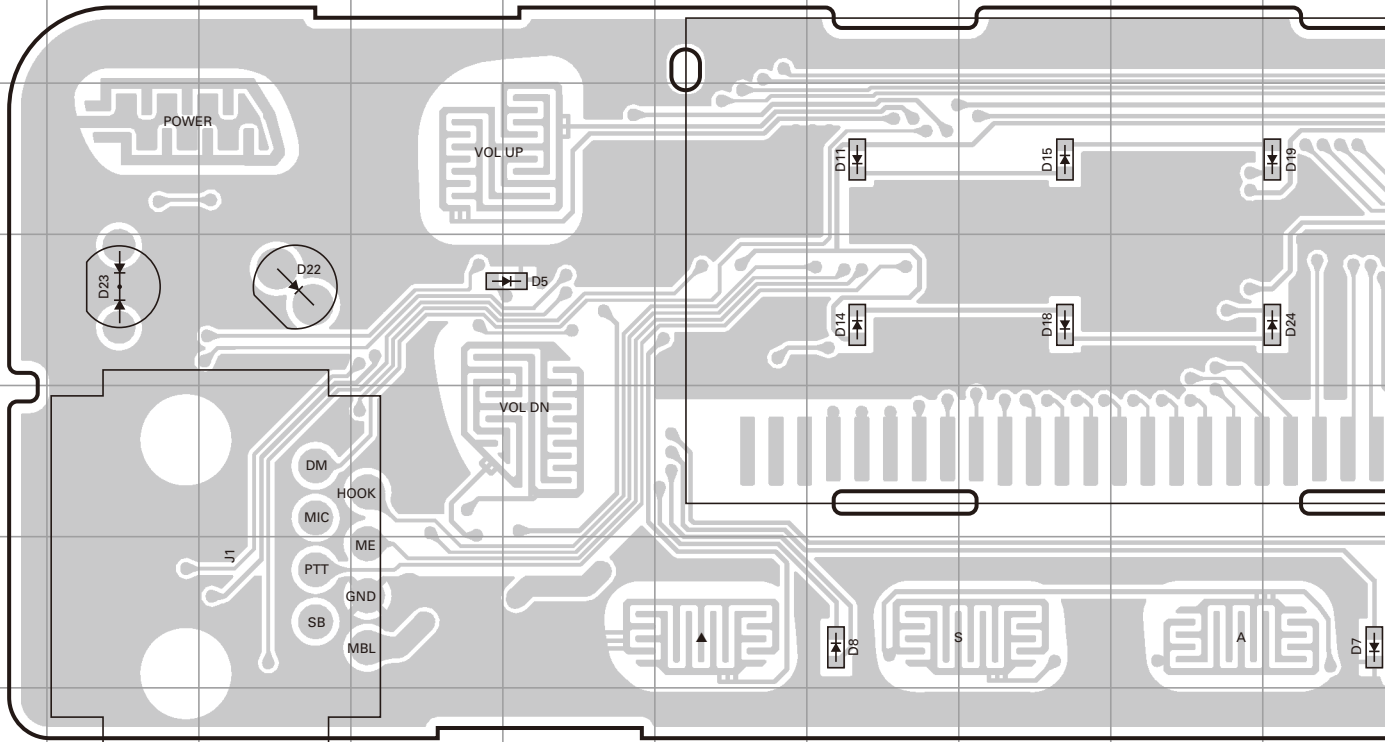

**DISPLAY UNIT (X54-3740-20) Foil side view (J79-0297-09)**

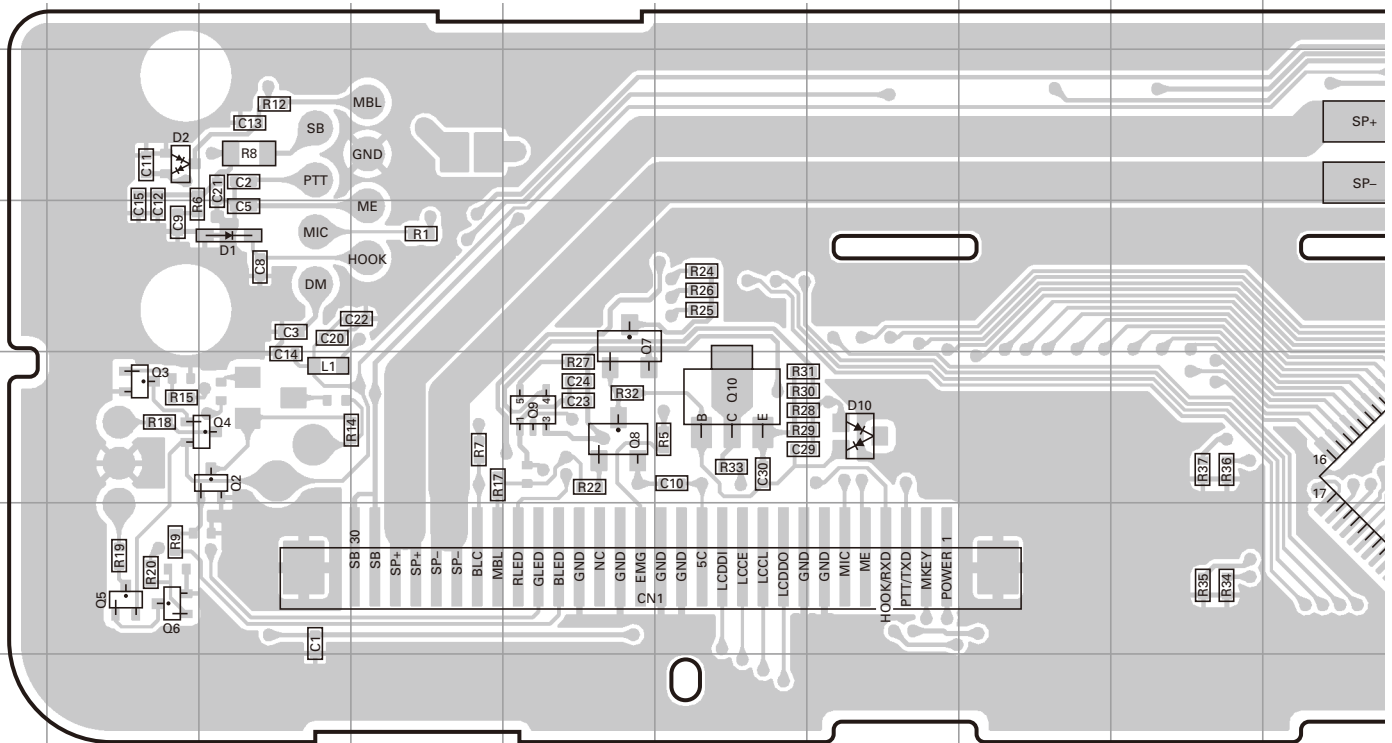

# PC BOARD TK-8360/8360H/8360H(U)

## DISPLAY UNIT (X54-3740-20) Component side view (J79-0297-09)

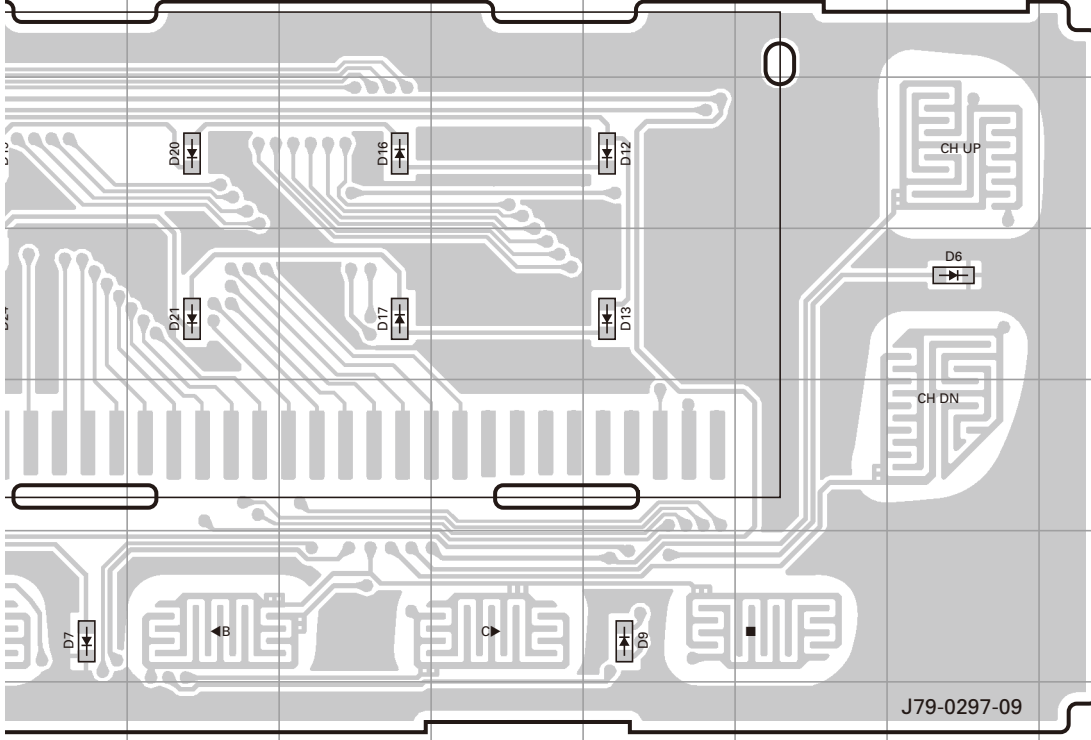

Ref. No.	Address	Ref. No.	Address
D5	4E	D16	3L
D6	4P	D17	4L
D7	6J	D18	4H
D8	6G	D19	3J
D9	6N	D20	3K
D11	3G	D21	4K
D12	3N	D22	4C
D13	4N	D23	4B
D14	4G	D24	4J
D15	3H		

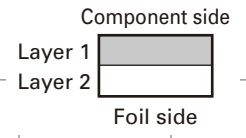

## DISPLAY UNIT (X54-3740-20) Foil side view (J79-0297-09)

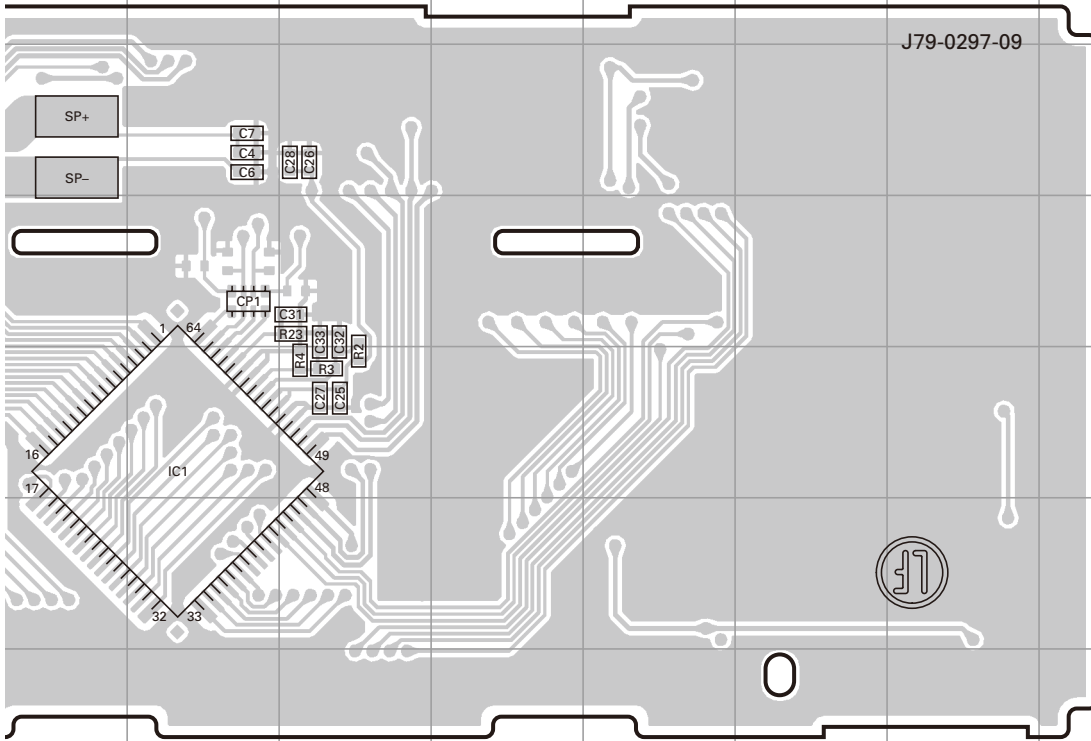

Ref. No.	Address
IC1	11K
Q2	11C
Q3	11B
Q4	11C
Q5	12B
Q6	12B
Q7	10E
Q8	11E
Q9	11E
Q10	11F
D1	10C
D2	9B
D10	11G

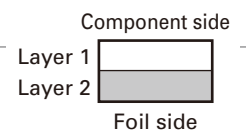

# TK-8360/8360H/8360H(U) PC BOARD

TX-RX UNIT (X57-8020-XX)

-11: TK-8360H K,M, TK-8360H(U) K -22: TK-8360 M

Component side view (J79-0296-09)

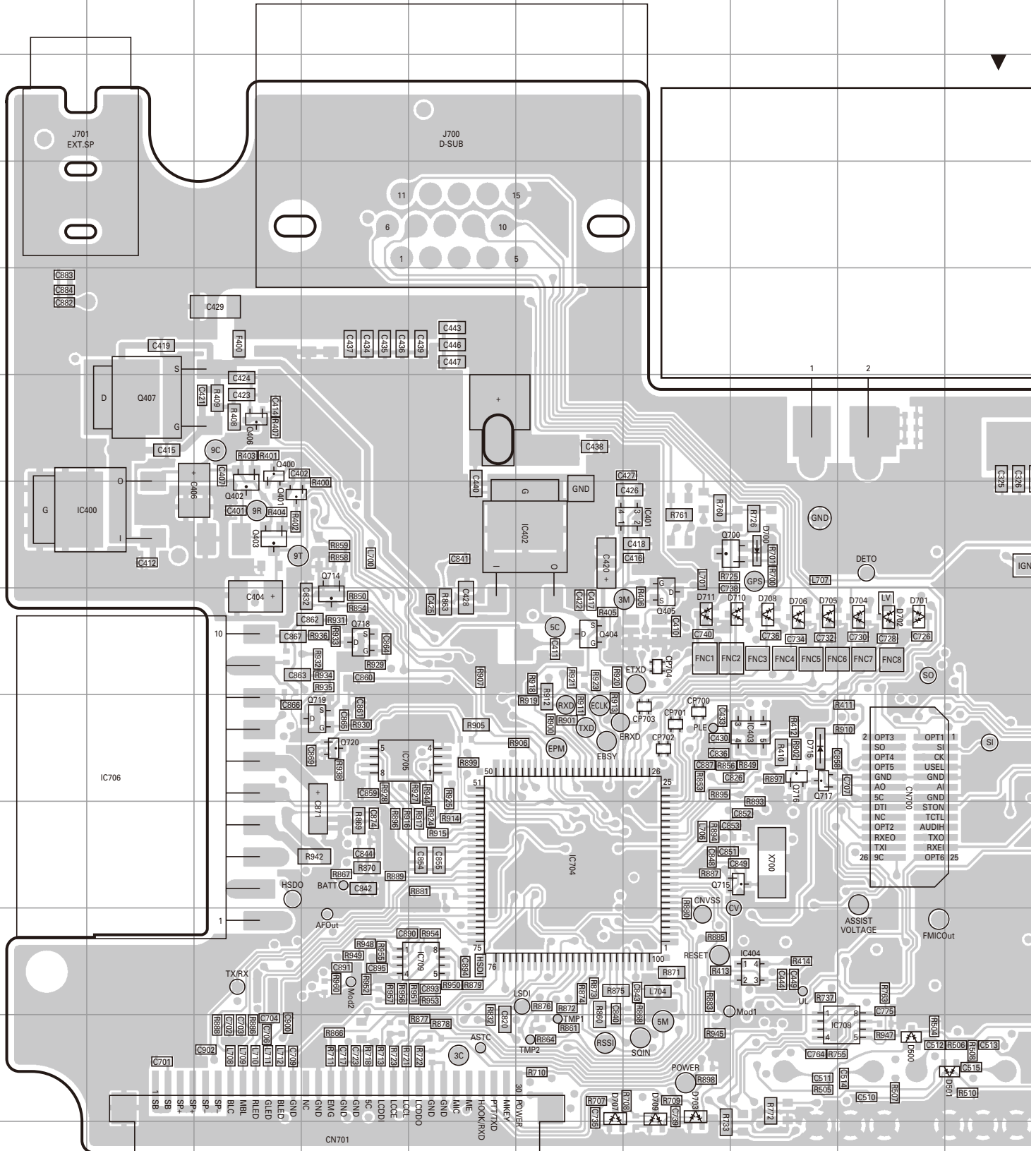

# PC BOARD TK-8360/8360H/8360H(U)

TX-RX UNIT (X57-8020-XX)

-11: TK-8360H K,M, TK-8360H(U) K -22: TK-8360 M

Component side view (J79-0296-09)

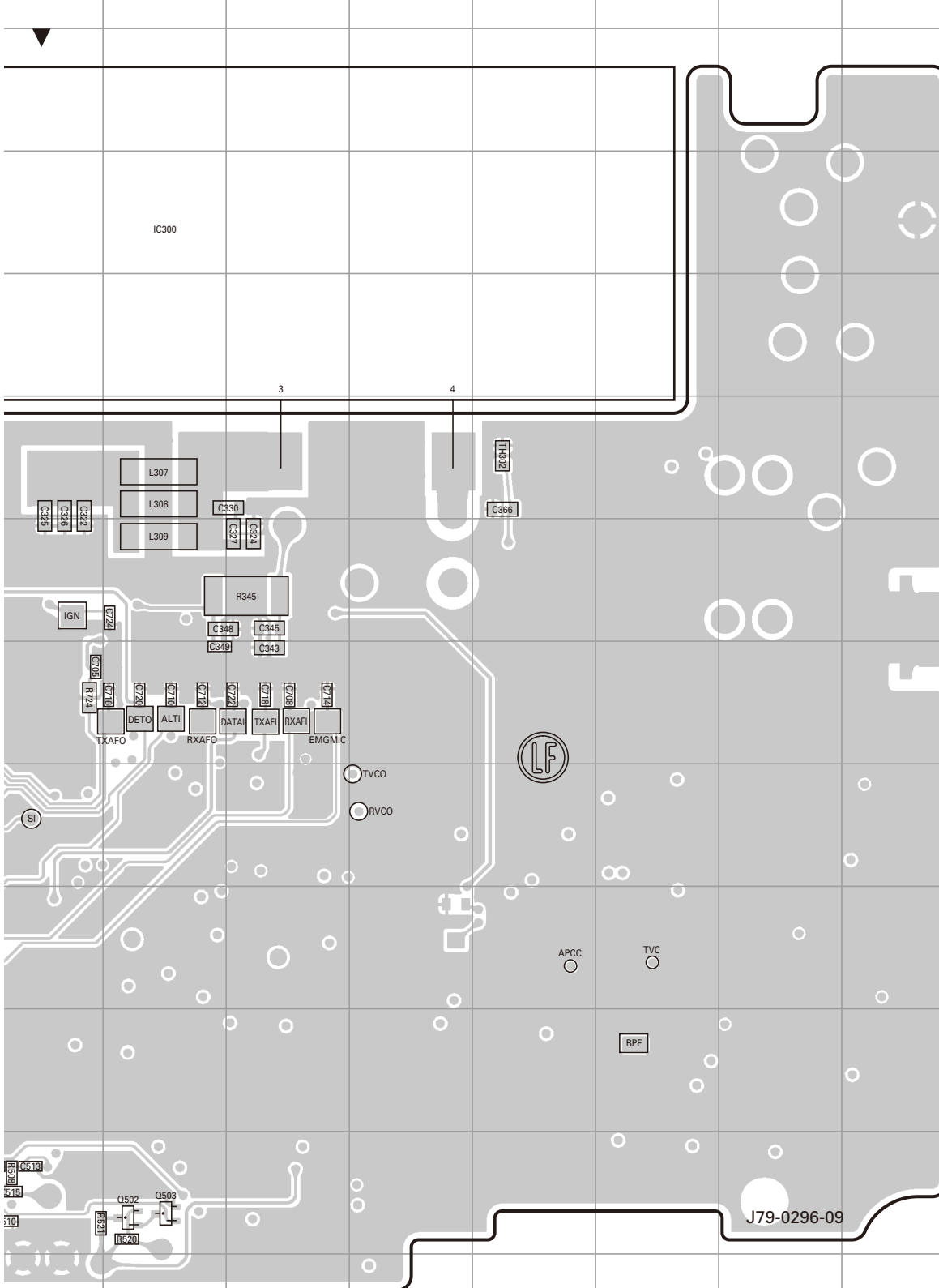

Ref. No.	Address
IC300	4K
IC400	7B
IC401	7G
IC402	7F
IC403	9H
IC404	11H
IC704	10F
IC705	9D
IC706	9B
IC708	12I
IC709	11E
Q400	6C
Q401	7C
Q402	7C
Q403	7C
Q404	8F
Q405	8G
Q406	6C
Q407	6B
Q502	12K
Q503	12K
Q700	7H
Q714	8D
Q715	10H
Q716	9H
Q717	9H
Q718	8D
Q719	9D
Q720	9D
D500	12I
D501	12J
D700	7H
D701	8I
D702	8I
D703	12G
D704	8I
D705	8H
D706	8H
D707	12F
D708	8H
D709	12G
D710	8H
D711	8G
D715	9H

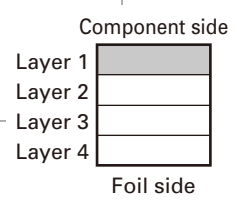

# TK-8360/8360H/8360H(U) PC BOARD

**TX-RX UNIT (X57-8020-XX)**

**-11: TK-8360H K,M, TK-8360H(U) K -22: TK-8360 M**

**Foil side view (J79-0296-09)**

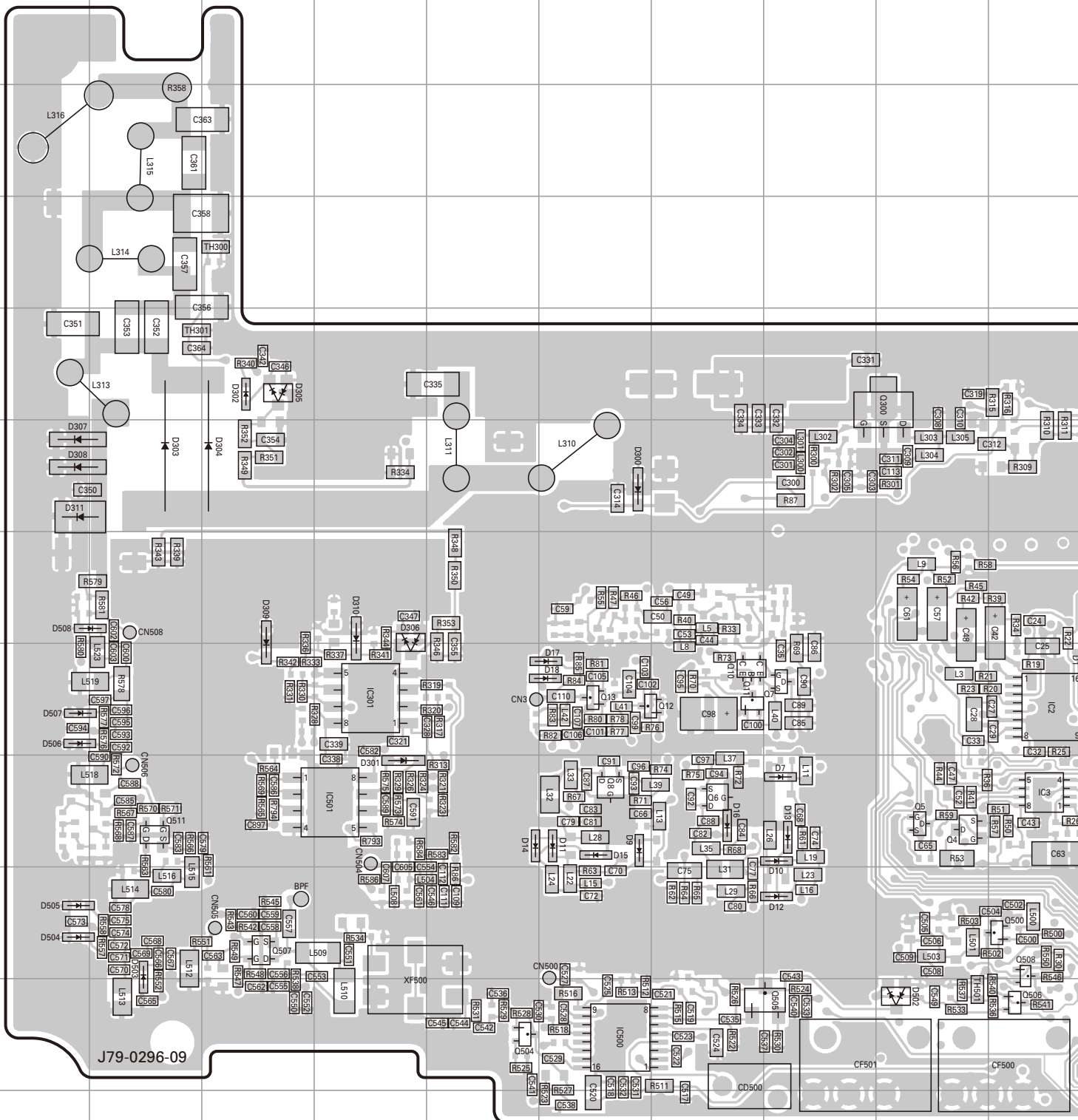



# PC BOARD TK-8360/8360H/8360H(U)

TX-RX UNIT (X57-8020-XX)

-11: TK-8360H K,M, TK-8360H(U) K -22: TK-8360 M

Foil side view (J79-0296-09)

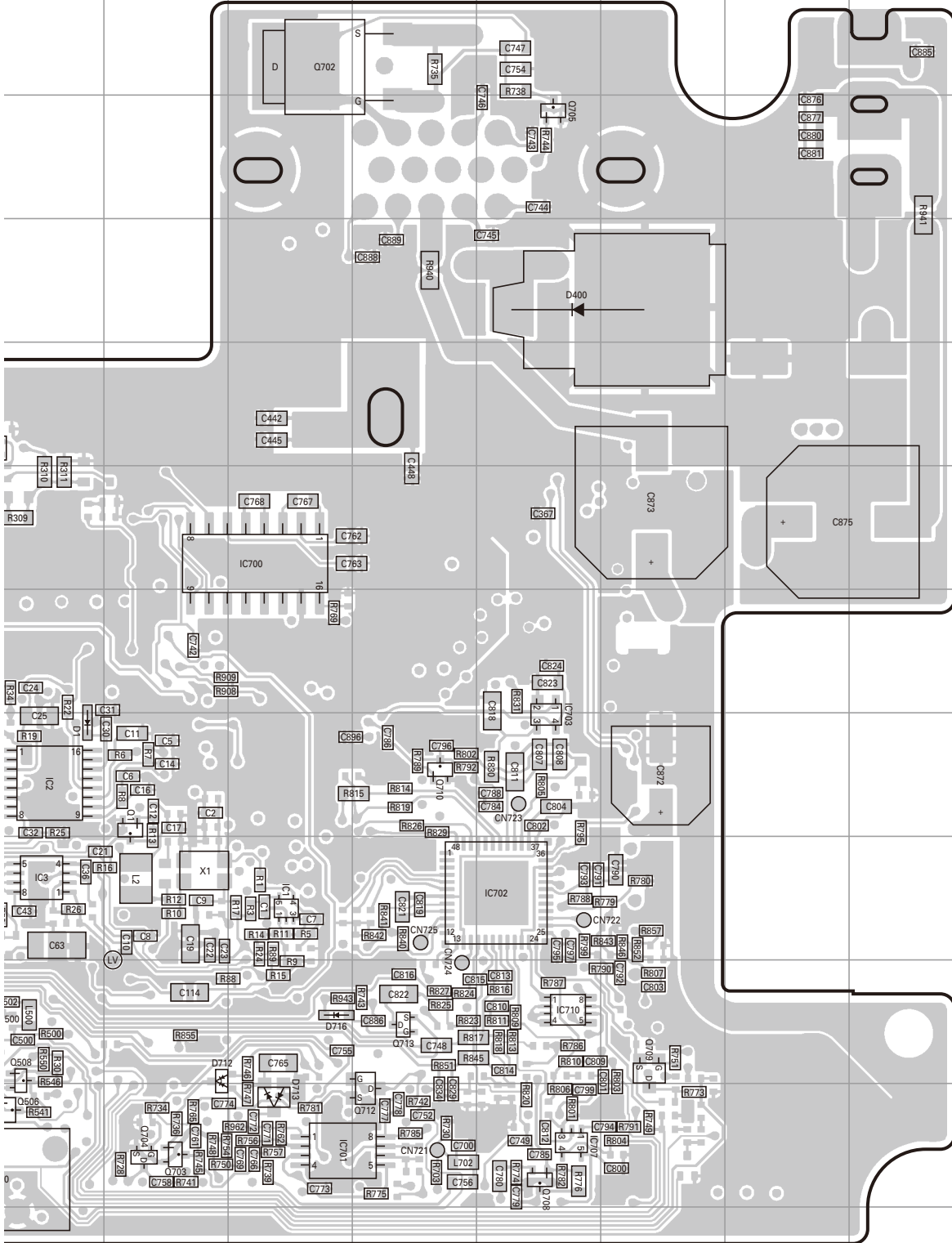

Ref. No.	Address	Ref. No.	Address
IC1	10L	Q712	12M
IC2	9J	Q713	11M
IC3	10J	D1	9J
IC301	9D	D7	10H
IC500	12F	D9	10F
IC501	10D	D10	10H
IC700	7L	D11	10F
IC701	12L	D12	11H
IC702	10N	D13	10H
IC703	9N	D14	10E
IC707	12N	D15	10F
IC710	11N	D16	10G
Q1	9K	D17	9F
Q4	10I	D18	9F
Q5	10I	D300	7F
Q6	10G	D301	10D
Q7	9H	D302	6C
Q8	10F	D303	7B
Q10	9G	D304	7C
Q11	9G	D305	6C
Q12	9G	D306	8D
Q13	9F	D307	7A
Q300	6I	D308	7A
Q500	11J	D309	8C
Q504	12E	D310	8D
Q505	12H	D311	7A
Q506	12J	D400	5N
Q507	11C	D502	12I
Q508	11J	D503	11B
Q511	10B	D504	11A
Q702	3L	D505	11A
Q703	12K	D506	9A
Q704	12K	D507	9A
Q705	4N	D508	8A
Q708	12N	D712	11K
Q709	11O	D713	12L
Q710	9M	D716	11L

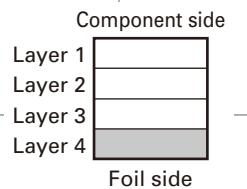

# TK-8360/8360H/8360H(U) SCHEMATIC DIAGRAM

TX-RX UNIT (X57-8020-XX)

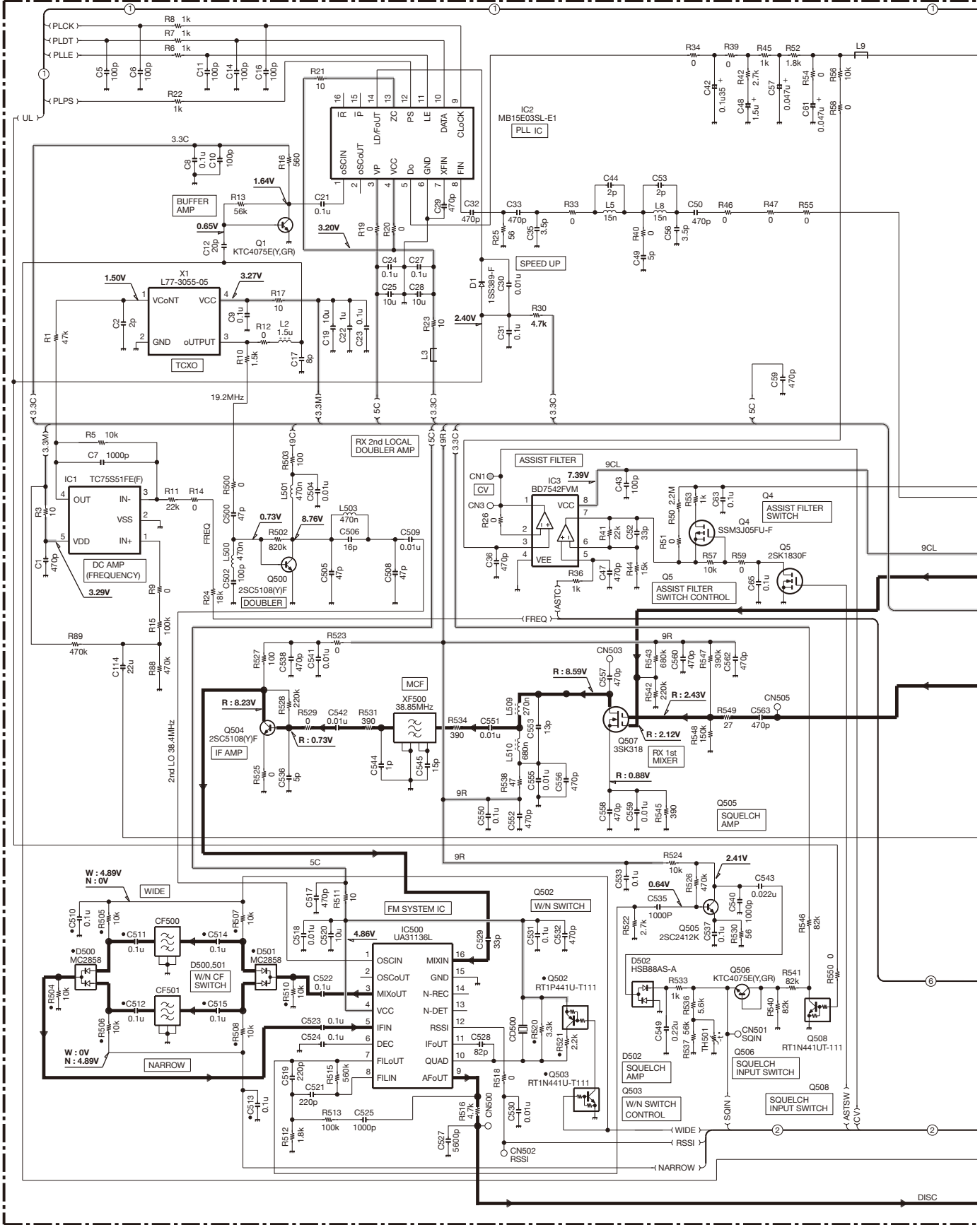

# SCHEMATIC DIAGRAM TK-8360/8360H/8360H(U)

TX-RX UNIT (X57-8020-XX)

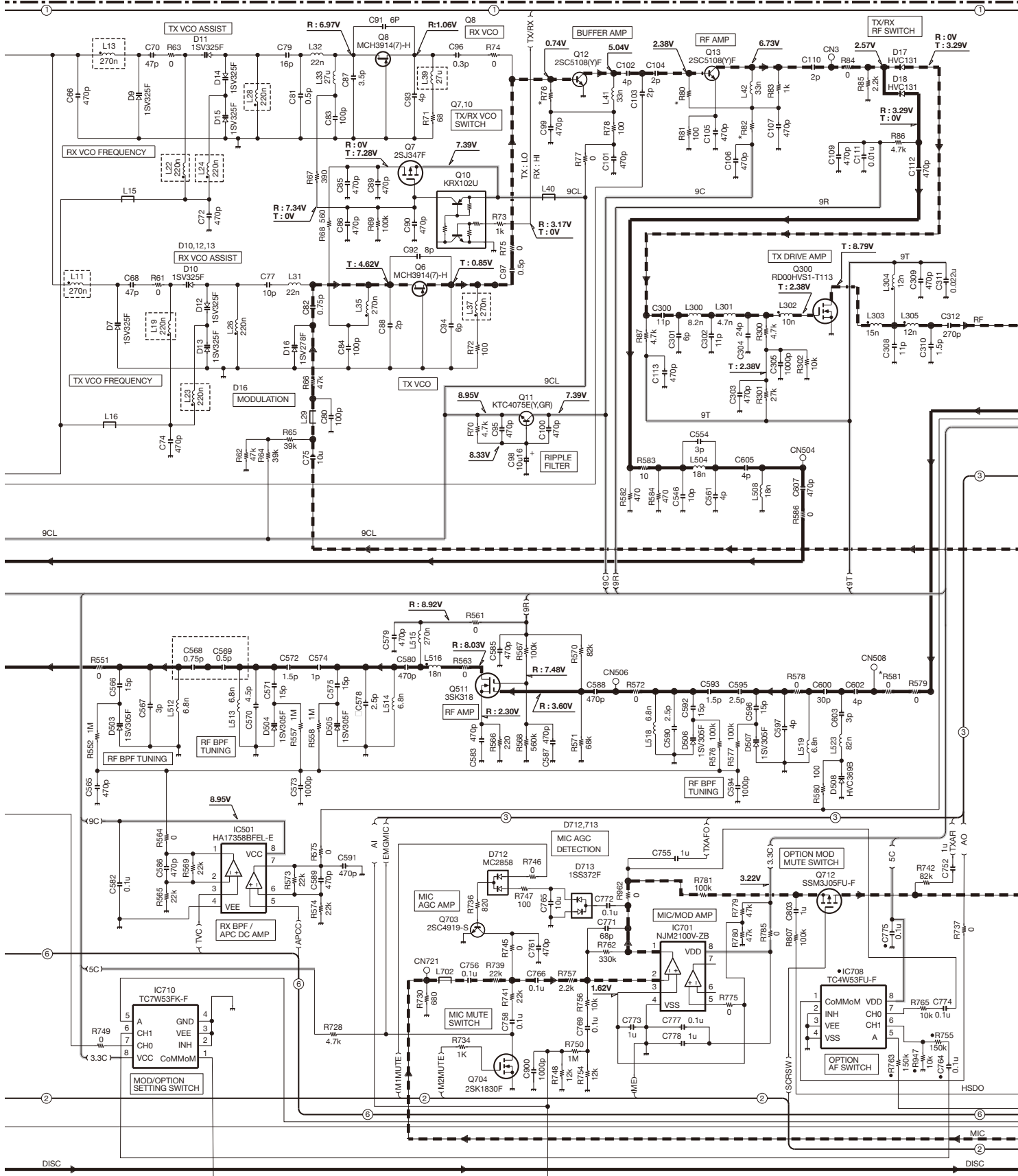

X57-8020-XX	R76	R80	R82
-22 TK-8360	M	56k	120k
-11 TK-8360H	K,M	120k	68k
TK-8360HU	K		100

# TK-8360/8360H/8360H(U) SCHEMATIC DIAGRAM

TX-RX UNIT (X57-8020-XX)

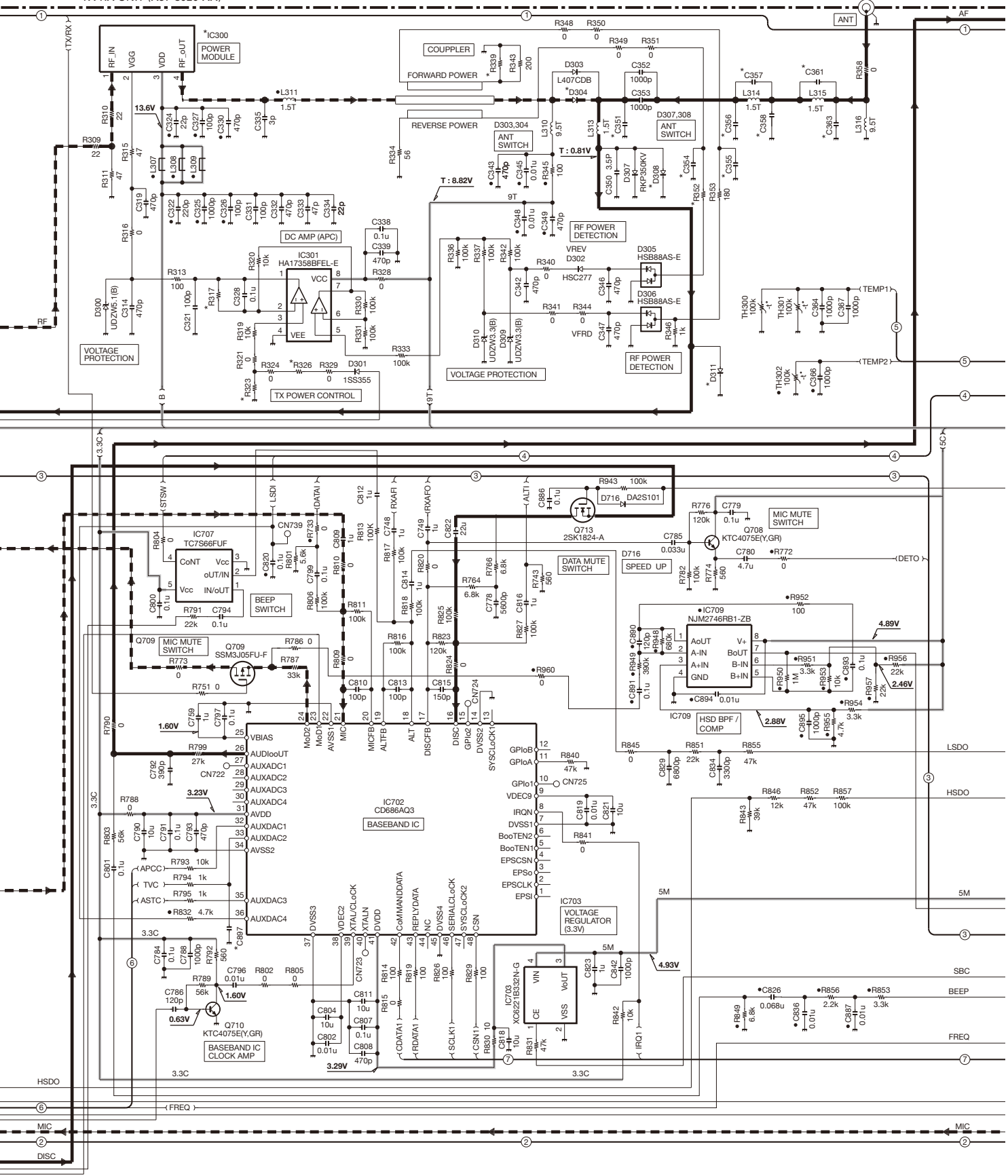

X57-8020-XX	C351	C354	C355	C356	C357	C358	C361	C363	C897	D304	D308	D311	L311	R317	R323	R326	R339	R352	IC300
-22 TK-8360	M	4p	11p	20p	6p	2p	6p	-	2p	470p	-	-	1.5T	330k	27k	47k	100	220	S-AU83AH
-11 TK-8360H	K	1p	9p	15p	2p	1p	4p	1p	3p	-	-	-	1.5T	220k	33k	22k	82	120	RA60H44521101

# SCHEMATIC DIAGRAM TK-8360/8360H/8360H(U)

TX-RX UNIT (X57-8020-XX)

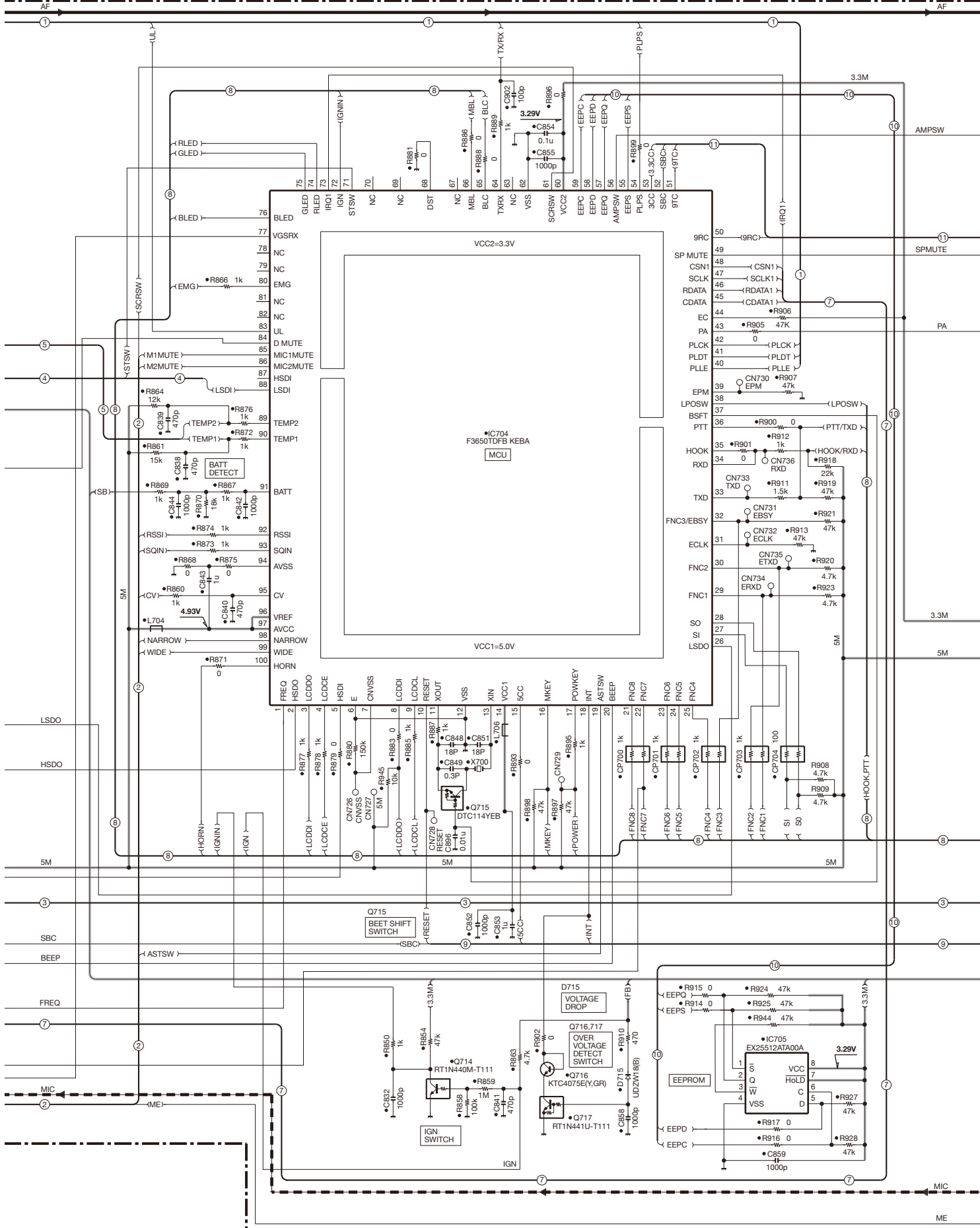

# TK-8360/8360H/8360H(U) SCHEMATIC DIAGRAM

TX-RX UNIT (X57-8020-XX)

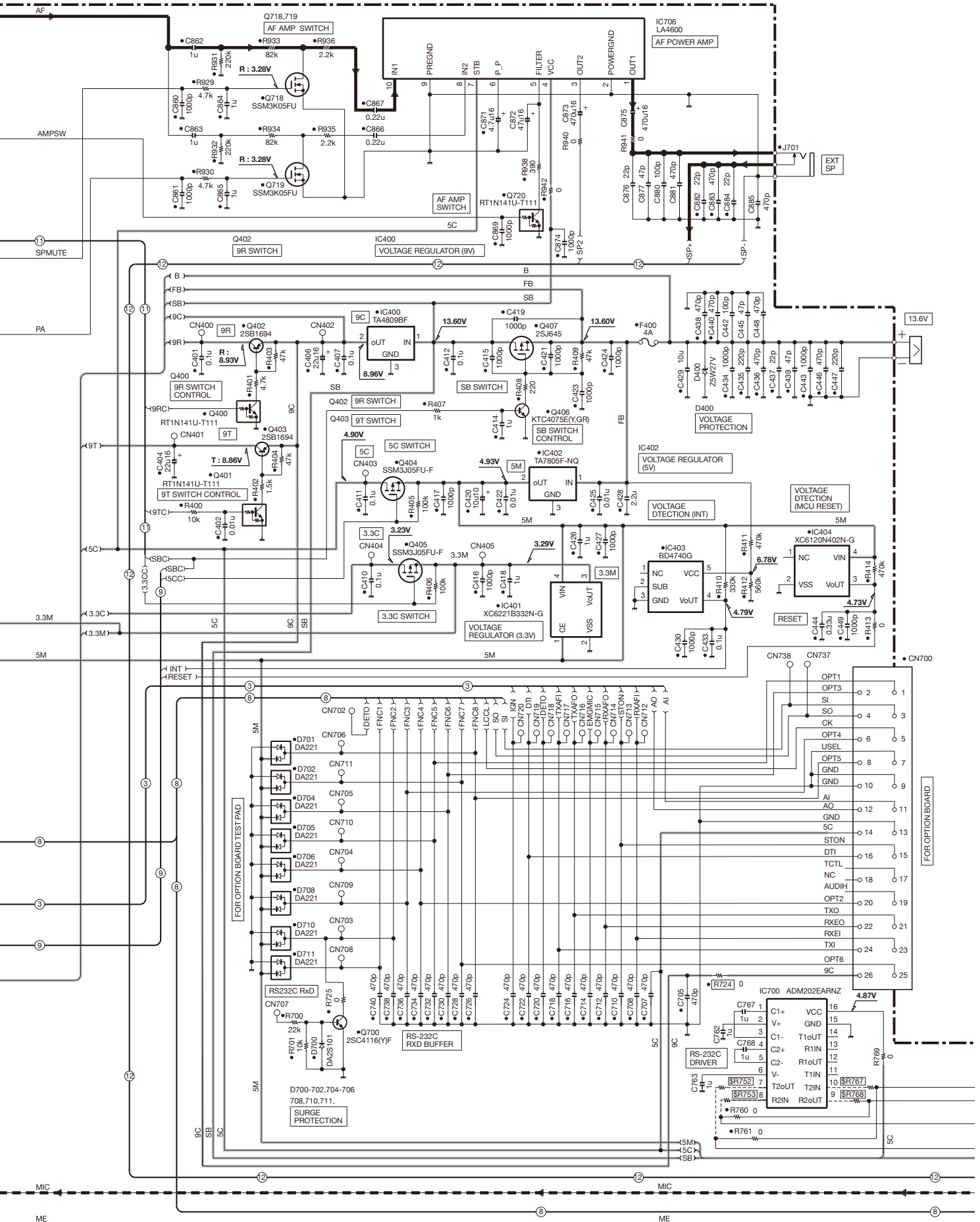

# SCHEMATIC DIAGRAM TK-8360/8360H/8360H(U)

Note : The components marked with a dot (•) are parts of layer 1.

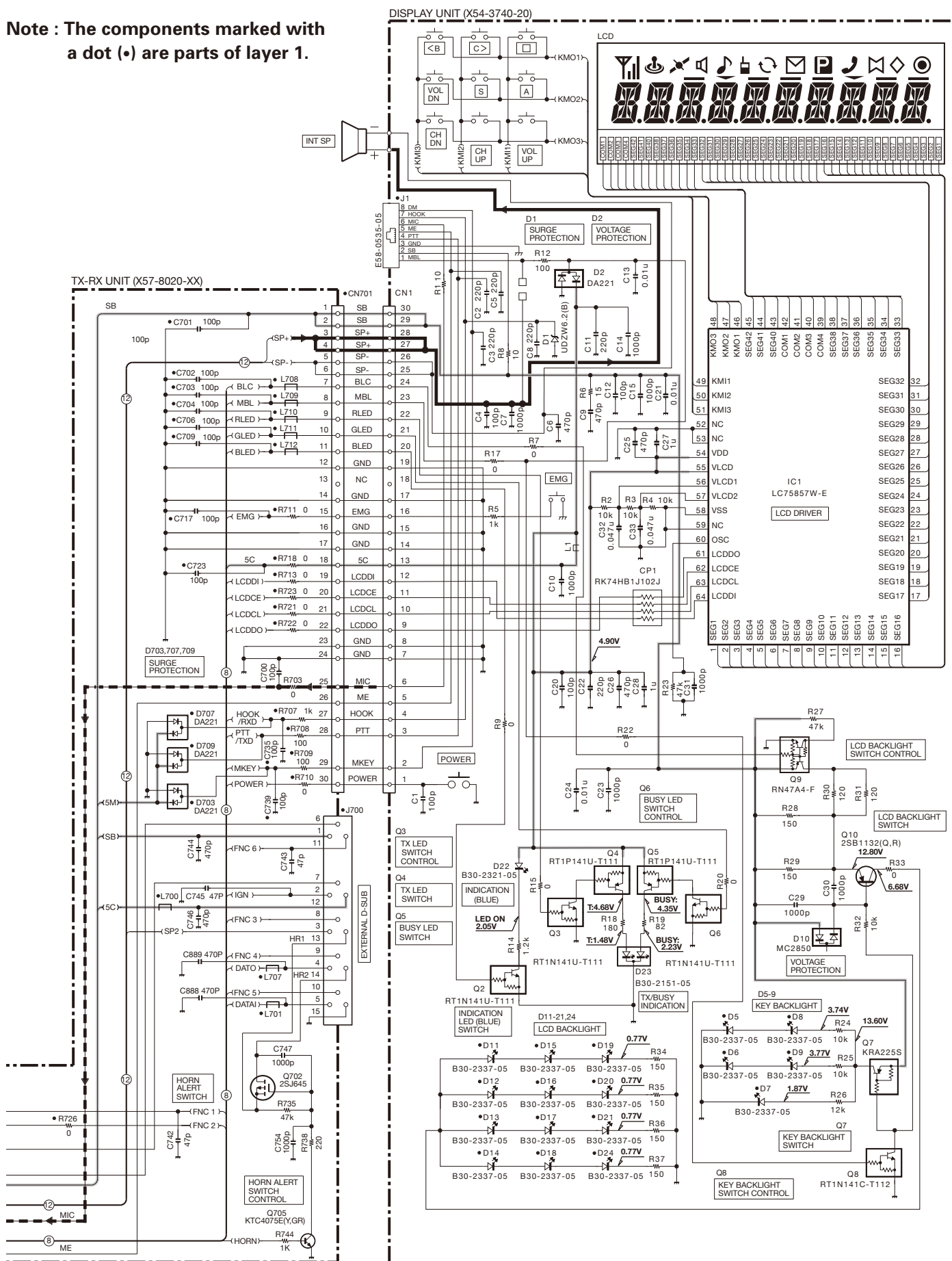

## BLOCK DIAGRAM

DISPLAY UNIT (X54-374)

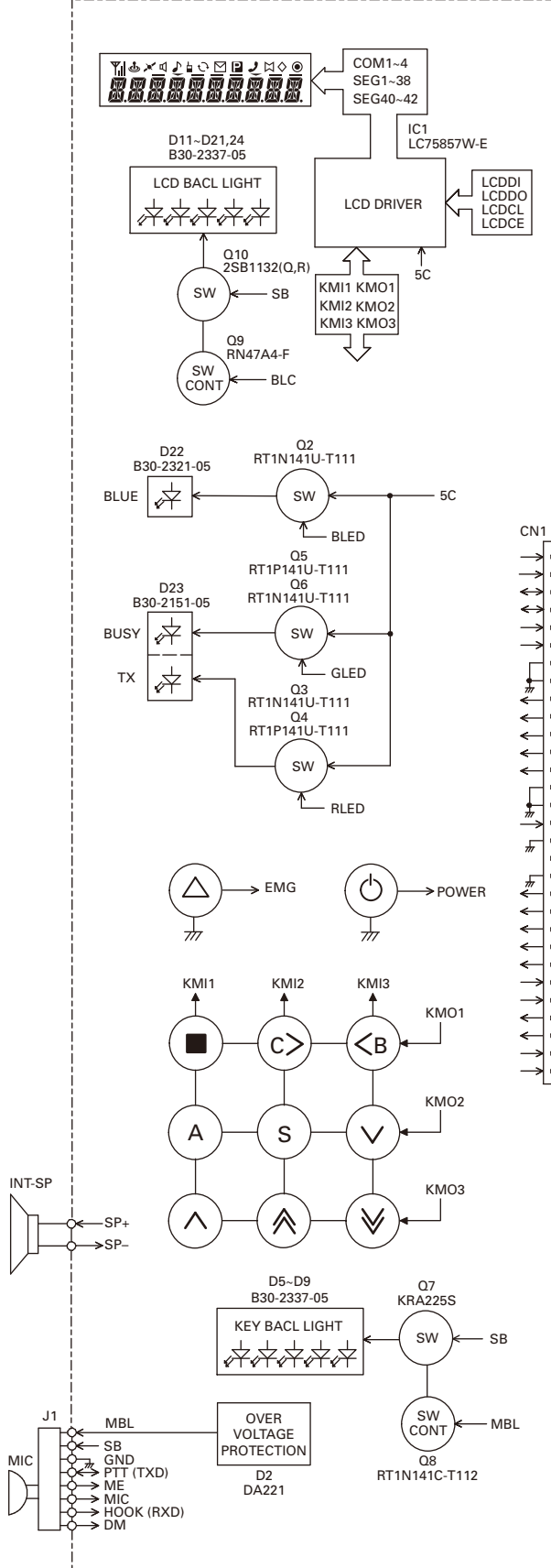

TX-RX UNIT (X57-802)

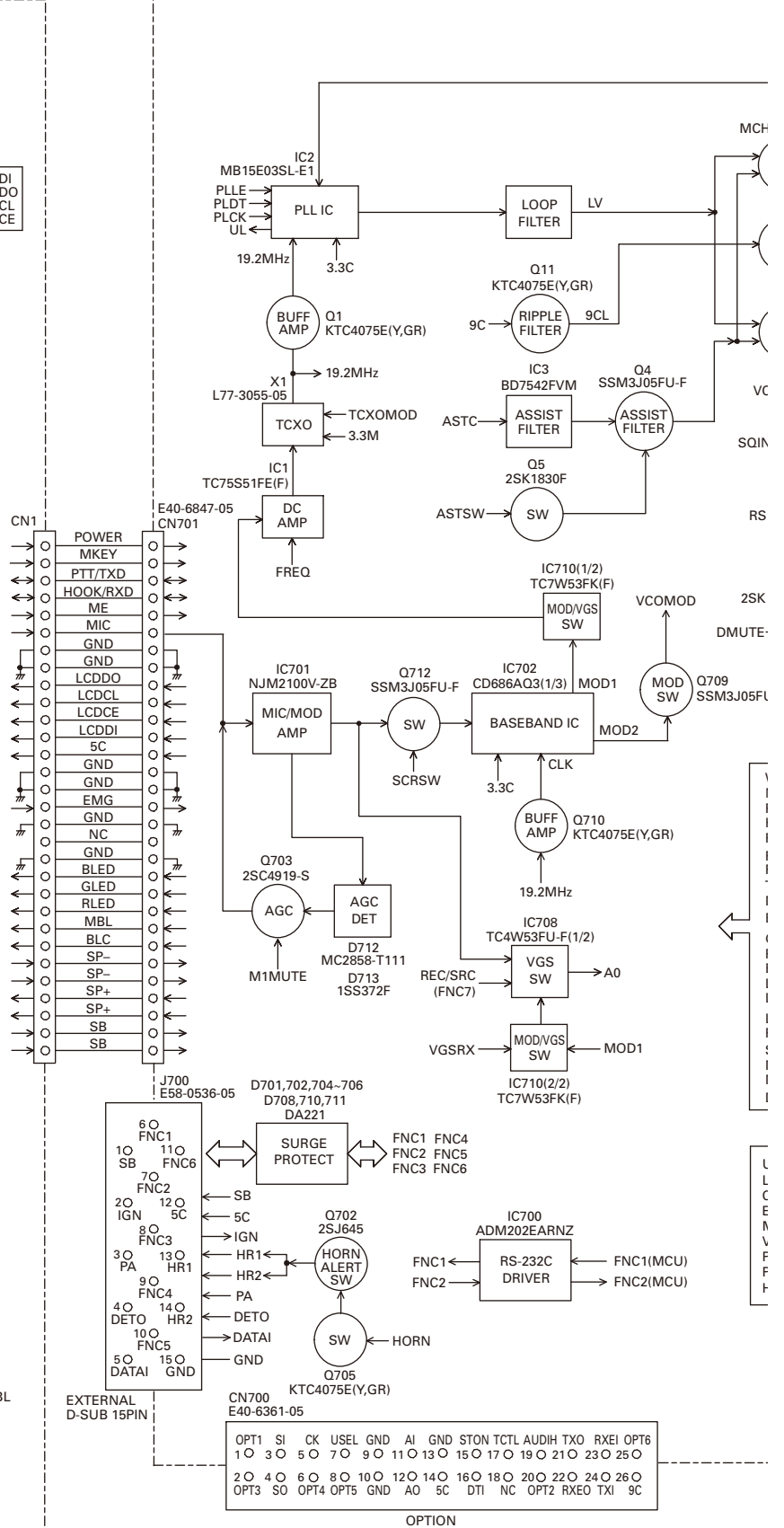



BLOCK DIAGRAM

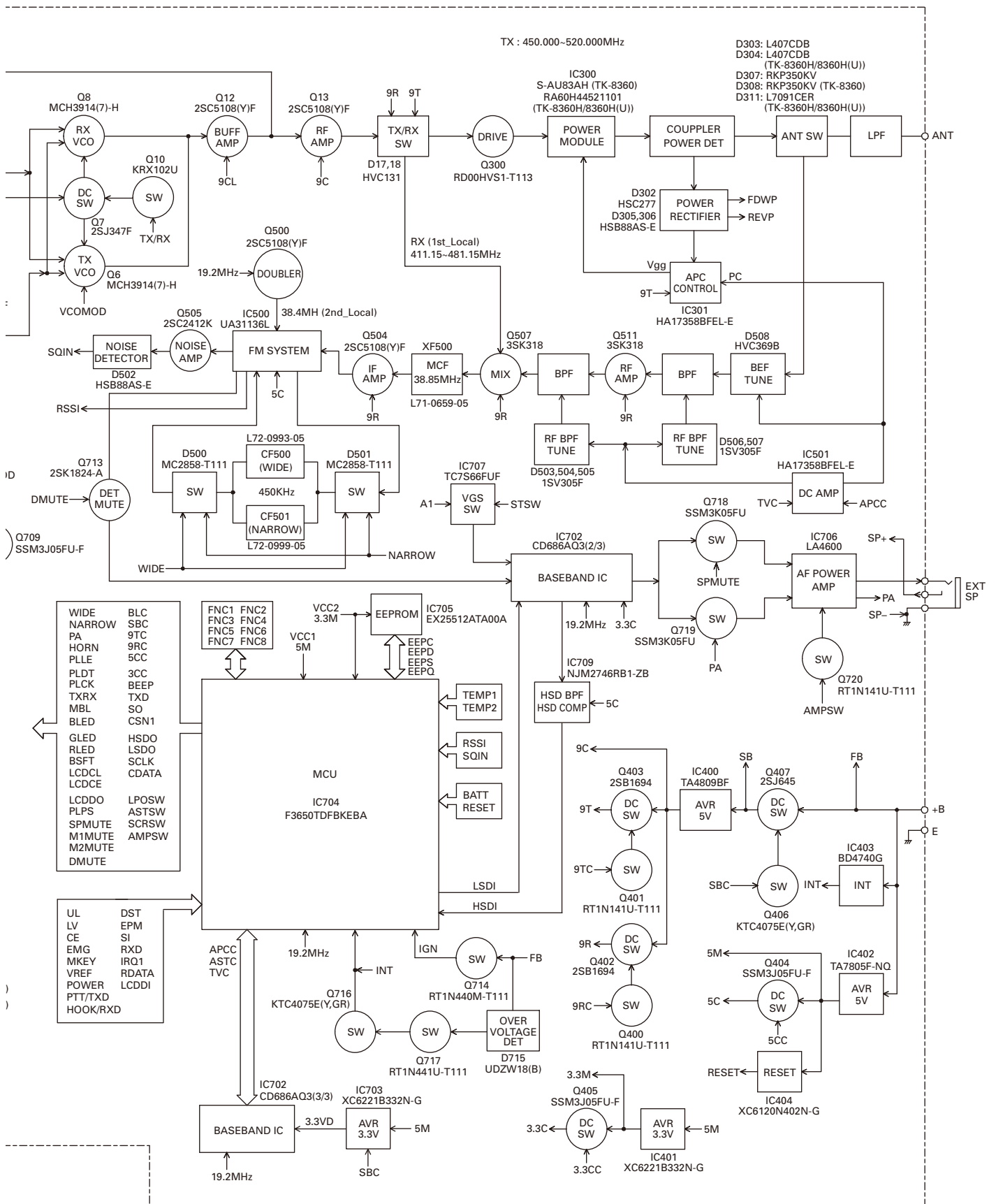

## LEVEL DIAGRAM

### Receiver Section

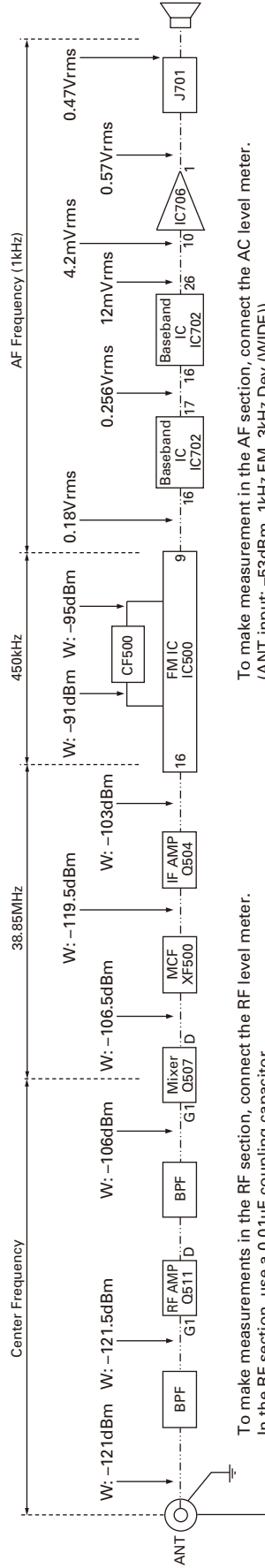

To make measurements in the RF section, connect the RF level meter.  
 In the RF section, use a 0.01μF coupling capacitor.  
 (The display shows the SSG input value required to obtain 12dB SINAD.)

To make measurements in the AF section, connect the AC level meter.  
 (ANT input: -53dBm, 1kHz FM, 3kHz Dev (WIDE))  
 The AF output level is adjusted for a 0.47V/4Ω by the front panel AF VOL control.

### Transmitter Section

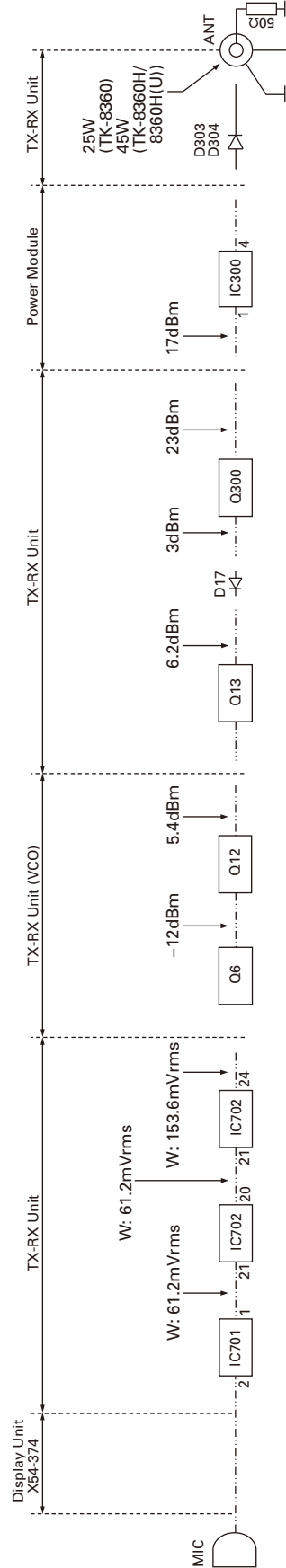

To make measurements in the AF section, connect the AC level meter.  
 AG is set so that MIC input becomes 3kHz (Wide) DEV at 1kHz MOD.

To make measurements in the RF section, connect the RF Wattmeter (500).

## SPECIFICATIONS

### GENERAL

Frequency Range.....	450 to 520MHz
Number of Channels.....	128
Zones.....	128
Channel Spacing.....	Wide: 25kHz      Narrow: 12.5kHz
Operating Voltage.....	13.6V DC $\pm$ 15%
Operating Temperature Range.....	-30°C to +60°C (-22°F to +140°F)
Frequency Stability.....	$\pm$ 2.5ppm
Antenna Impedance.....	50 $\Omega$
Dimensions (W x H x D) (Projections not included).....	160 x 43 x 136 mm (6.30 x 1.69 x 5.35 in)
Weight (net).....	1.2kg (2.6 lb)

### RECEIVER (Measurements made per EIA/TIA-603)

Sensitivity (12dB SINAD).....	Wide: 0.28 $\mu$ V      Narrow: 0.35 $\mu$ V
Selectivity.....	Wide: 75dB      Narrow: 65dB
Intermodulation Distortion.....	Wide: 70dB      Narrow: 65dB
Spurious Response.....	75dB
Audio Output (4 $\Omega$ impedance).....	4W with less than 5% distortion

### TRANSMITTER (Measurements made per EIA/TIA-603)

RF Power Output	
TK-8360.....	5~25W (High: 25W, Low: 5W)
TK-8360H/8360H(U).....	5~45W (High: 45W, Mid: 25W, Low: 25W)
Spurious Response.....	70dB
FM Hum & Noise.....	Wide: 45dB      Narrow: 40dB
Audio Distortion.....	Wide: Less than 3%      Narrow: Less than 5%
Modulation.....	Wide: 16K0F3E      Narrow: 11K0F3E

Measurements made per TIA/EIA-603 and specifications shown are typical.

Kenwood reserves the right to change specifications without prior notice or obligation.

# TK-8360/8360H/8360H(U)

## Kenwood Corporation

2967-3, Ishikawa-machi, Hachioji-shi, Tokyo, 192-8525 Japan

### Kenwood U.S.A. Corporation

P.O. BOX 22745, 2201 East Dominguez Street, Long Beach,  
CA 90801-5745, U.S.A.

### Kenwood Electronics Canada Inc.

6070 Kestrel Road, Mississauga, Ontario, Canada L5T 1S8

### Kenwood Electronics Deutschland GmbH

Rembrücker Str. 15, 63150 Heusenstamm, Germany

### Kenwood Electronics Belgium N.V.

Leuvensesteenweg 248 J, 1800 Vilvoorde, Belgium

### Kenwood Electronics France S.A.

L'Etoile Paris Nord 2, 50 Allée des Impressionnistes,  
Bp 58416 Villepinte, 95944 Roissy Ch De Gaulle Cedex

### Kenwood Electronics UK Limited

KENWOOD House, Dwight Road, Watford, Herts.,  
WD18 9EB United Kingdom

### Kenwood Electronics Europe B.V.

Amsterdamseweg 37, 1422 AC Uithoorn, The Netherlands

### Kenwood Electronics Italia S.p.A.

Via G. Sirtori, 7/9 20129 Milano, Italy

### Kenwood Ibérica, S.A.

Bolivia, 239-08020 Barcelona, Spain

### Kenwood Electronics Australia Pty. Ltd.

Talavera Business Park Building A, 4 Talavera Road,  
North Ryde NSW 2113 Australia

### Kenwood Electronics (Hong Kong) Ltd.

Suite 2504, 25/F, Tower 2, Nina Tower, No. 8 Yeung Uk Road,  
Tsuen Wan, New Territories, Hong Kong

### Kenwood Electronics Singapore Pte Ltd

1 Ang Mo Kio Street 63, Singapore 569110

DISPLAY UNIT (X54-3740-20) Component side view (J79-0297-09)

DISPLAY UNIT (X54-3740-20) Component side view (J79-0297-09)

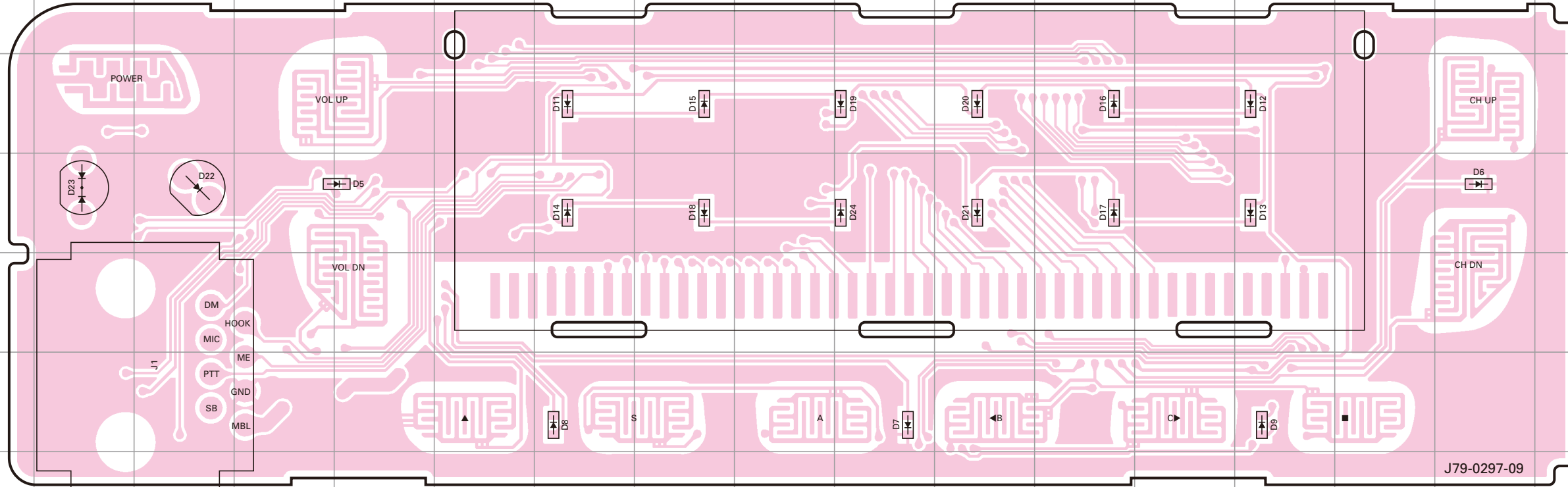

Ref. No.	Address	Ref. No.	Address
D5	4E	D16	3L
D6	4P	D17	4L
D7	6J	D18	4H
D8	6G	D19	3J
D9	6N	D20	3K
D11	3G	D21	4K
D12	3N	D22	4C
D13	4N	D23	4B
D14	4G	D24	4J
D15	3H		

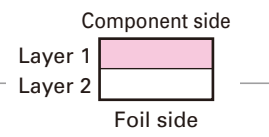

DISPLAY UNIT (X54-3740-20) Foil side view (J79-0297-09)

DISPLAY UNIT (X54-3740-20) Foil side view (J79-0297-09)

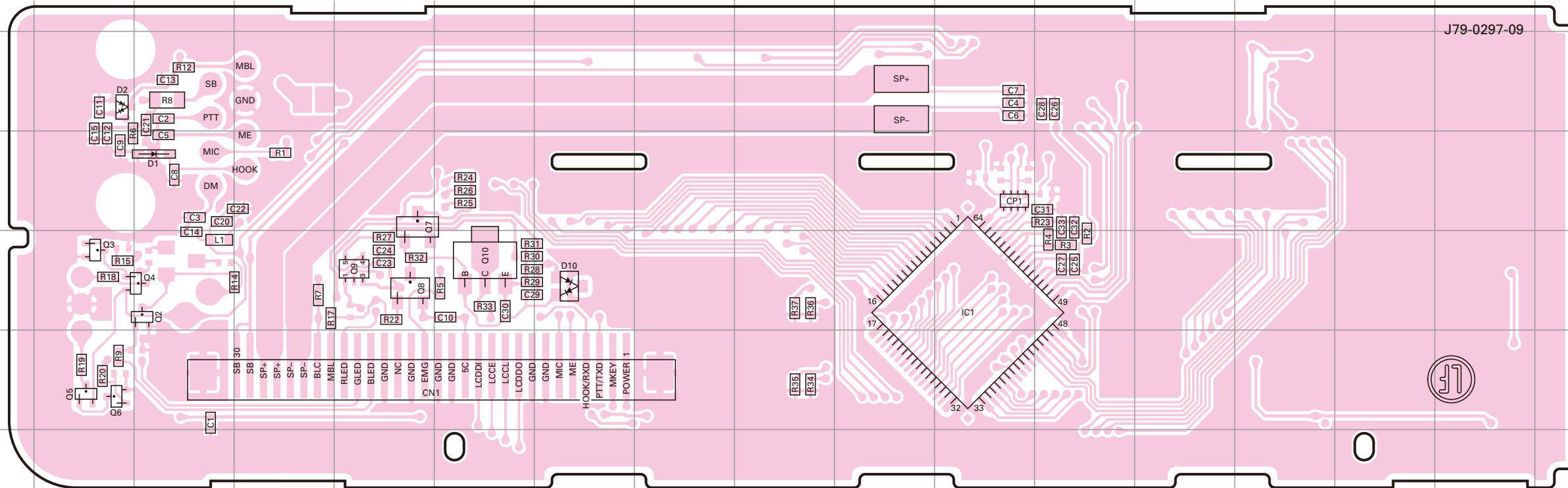

Ref. No.	Address
IC1	11K
Q2	11C
Q3	11B
Q4	11C
Q5	12B
Q6	12B
Q7	10E
Q8	11E
Q9	11E
Q10	11F
D1	10C
D2	9B
D10	11G

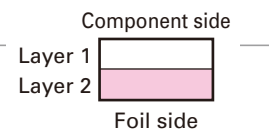

# TK-8360/8360H/8360H(U) PC BOARD

TX-RX UNIT (X57-8020-XX)  
 -11: TK-8360H K,M, TK-8360H(U) K -22: TK-8360 M  
 Component side view (J79-0296-09)

# PC BOARD TK-8360/8360H/8360H(U)

TX-RX UNIT (X57-8020-XX)  
 -11: TK-8360H K,M, TK-8360H(U) K -22: TK-8360 M  
 Component side view (J79-0296-09)

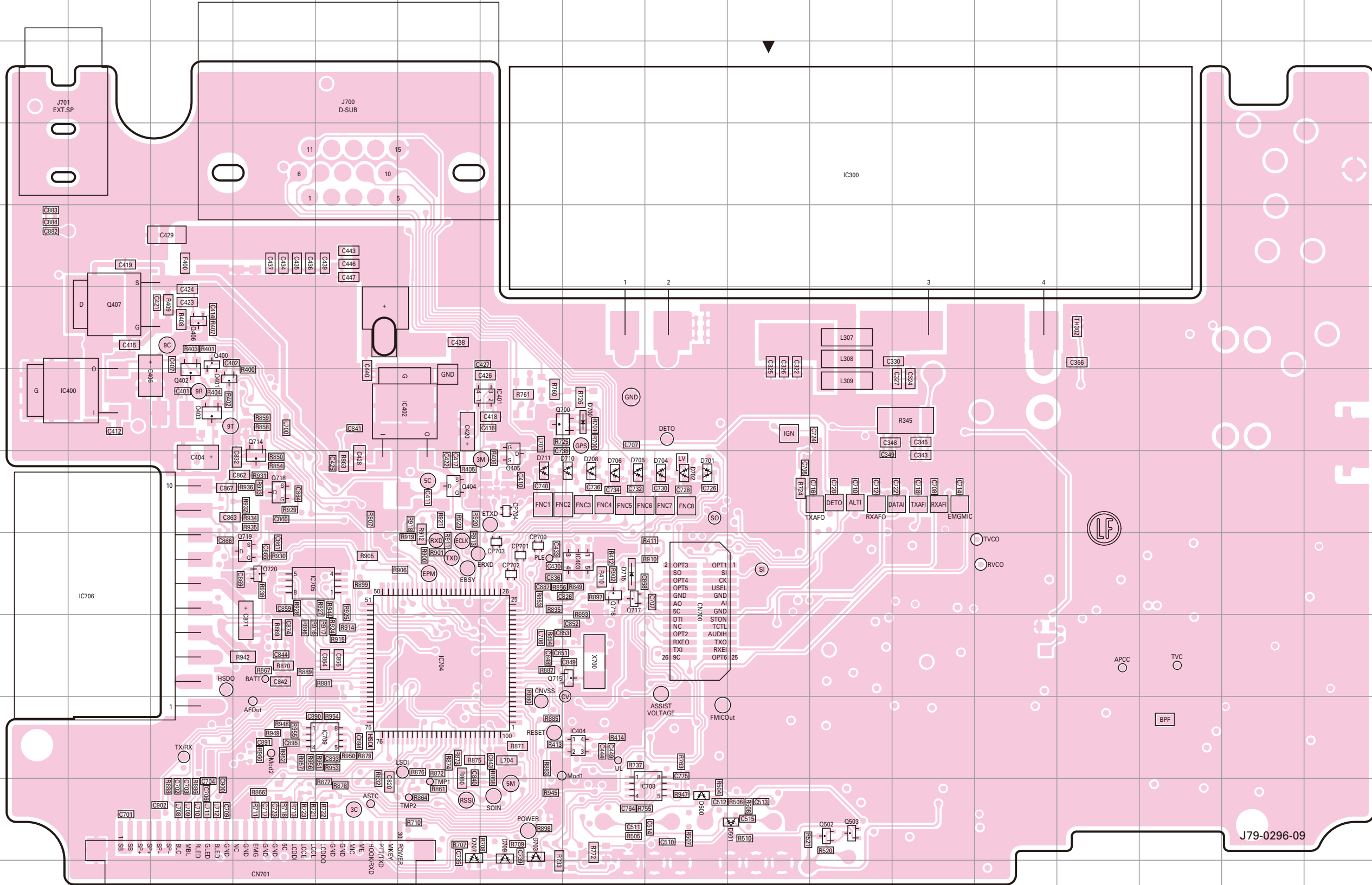

Ref. No.	Address
IC300	4K
IC400	7B
IC401	7G
IC402	7F
IC403	9H
IC404	11H
IC704	10F
IC705	9D
IC706	9B
IC708	12I
IC709	11E
Q400	6C
Q401	7C
Q402	7C
Q403	7C
Q404	8F
Q405	8G
Q406	6C
Q407	6B
Q502	12K
Q503	12K
Q700	7H
Q714	8D
Q715	10H
Q716	9H
Q717	9H
Q718	8D
Q719	9D
Q720	9D
D500	12I
D501	12J
D700	7H
D701	8I
D702	8I
D703	12G
D704	8I
D705	8H
D706	8H
D707	12F
D708	8H
D709	12G
D710	8H
D711	8G
D715	9H

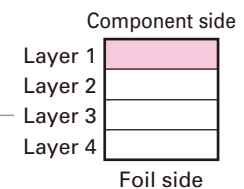

# TK-8360/8360H/8360H(U) PC BOARD

# PC BOARD TK-8360/8360H/8360H(U)

**TX-RX UNIT (X57-8020-XX)**  
**-11: TK-8360H K,M, TK-8360H(U) K -22: TK-8360 M**  
**Foil side view (J79-0296-09)**

**TX-RX UNIT (X57-8020-XX)**  
**-11: TK-8360H K,M, TK-8360H(U) K -22: TK-8360 M**  
**Foil side view (J79-0296-09)**

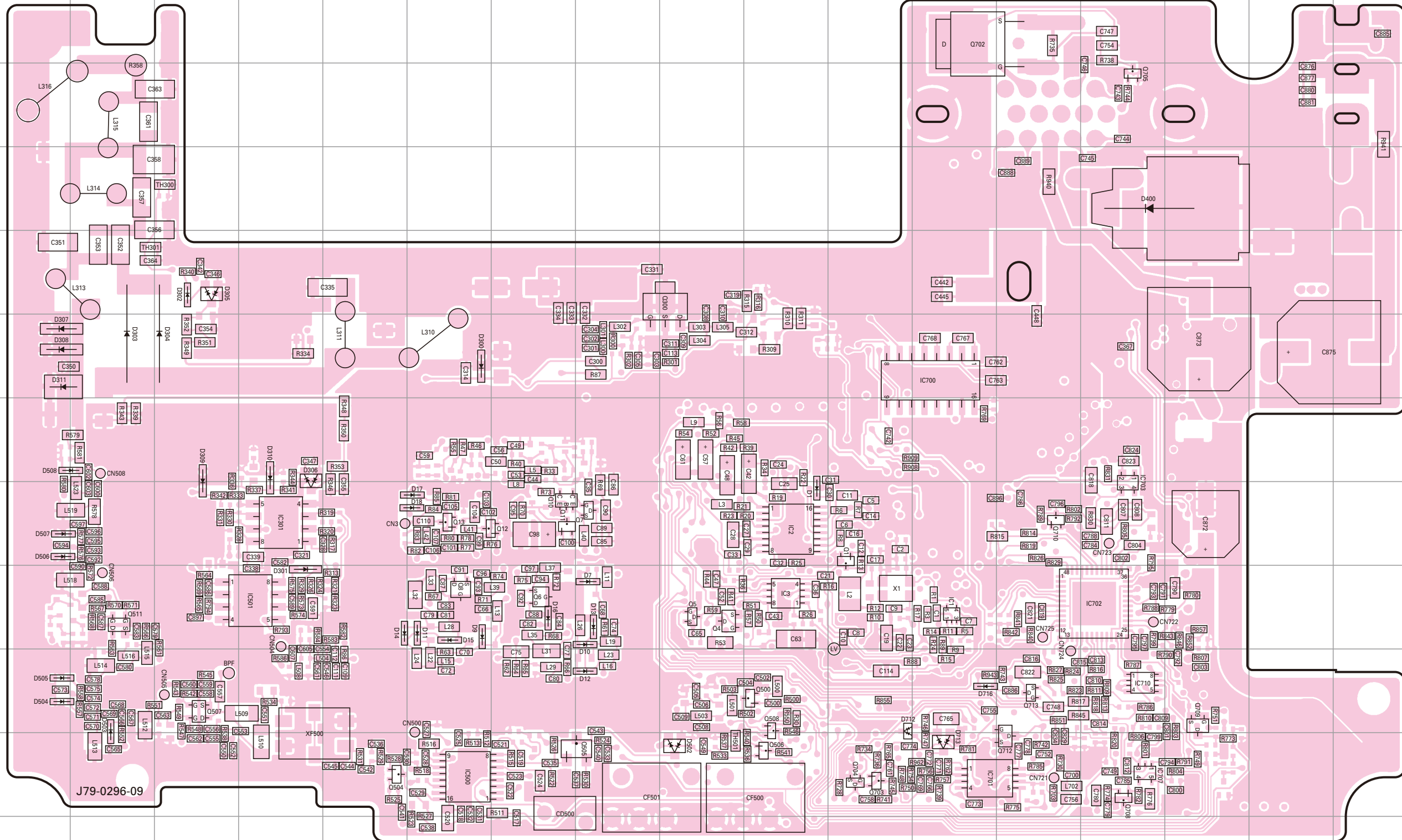

Ref. No.	Address	Ref. No.	Address
IC1	10L	Q712	12M
IC2	9J	Q713	11M
IC3	10J	D1	9J
IC301	9D	D7	10H
IC500	12F	D9	10F
IC501	10D	D10	10H
IC700	7L	D11	10F
IC701	12L	D12	11H
IC702	10N	D13	10H
IC703	9N	D14	10E
IC707	12N	D15	10F
IC710	11N	D16	10G
Q1	9K	D17	9F
Q4	10I	D18	9F
Q5	10I	D300	7F
Q6	10G	D301	10D
Q7	9H	D302	6C
Q8	10F	D303	7B
Q10	9G	D304	7C
Q11	9G	D305	6C
Q12	9G	D306	8D
Q13	9F	D307	7A
Q300	6I	D308	7A
Q500	11J	D309	8C
Q504	12E	D310	8D
Q505	12H	D311	7A
Q506	12J	D400	5N
Q507	11C	D502	12I
Q508	11J	D503	11B
Q511	10B	D504	11A
Q702	3L	D505	11A
Q703	12K	D506	9A
Q704	12K	D507	9A
Q705	4N	D508	8A
Q708	12N	D712	11K
Q709	11O	D713	12L
Q710	9M	D716	11L

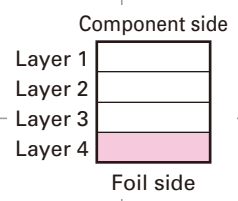





DISPLAY UNIT (X54-374)

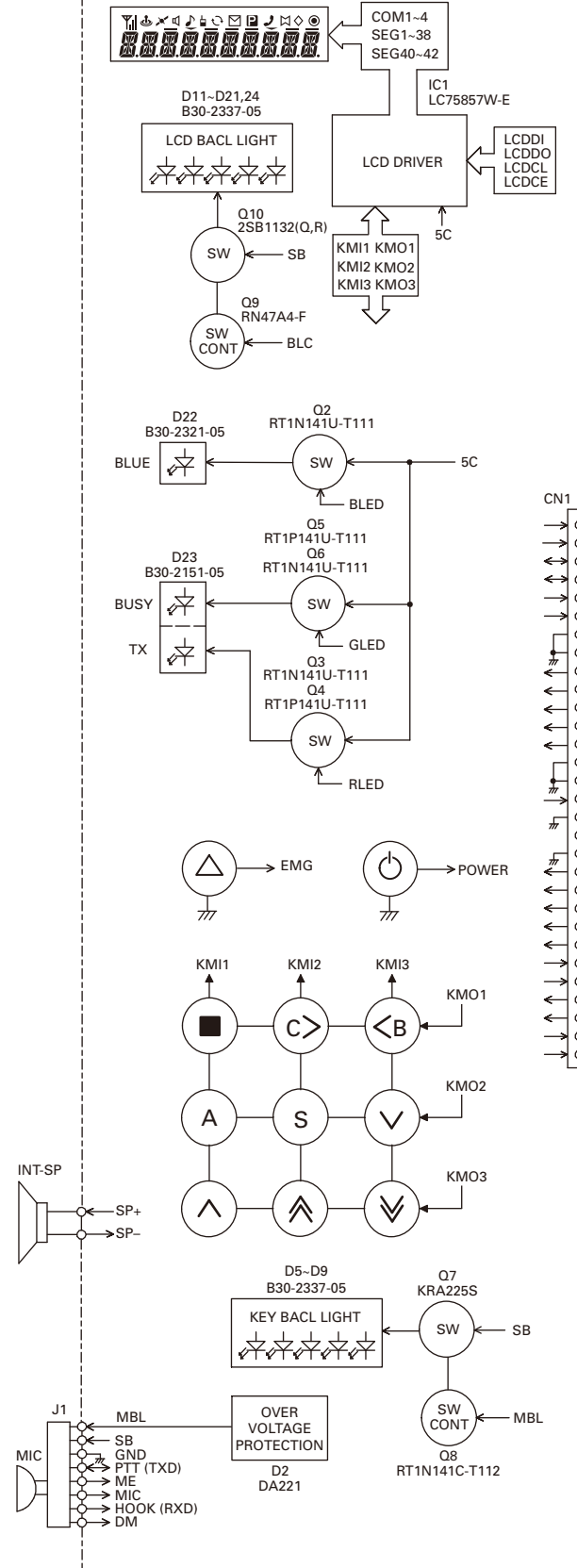

TX-RX UNIT (X57-802)

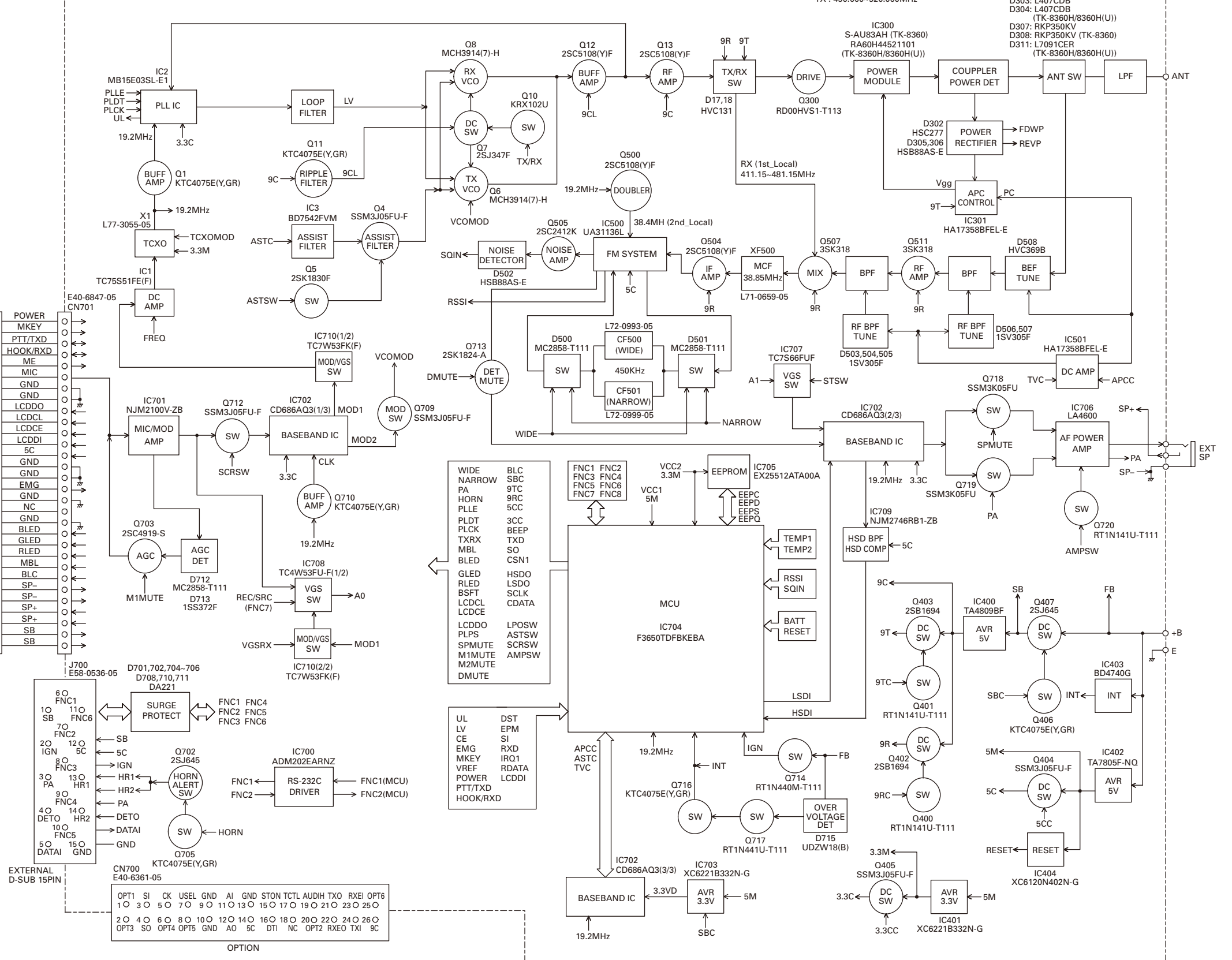

CN1

POWER	EMG
MKEY	POWER
PTT/TXD	
HOOK/RXD	
ME	
MIC	
GND	
LCDDO	
LCDCI	
LCDCD	
LCDCD	
EMG	
NC	
GND	
BLEDD	
GLED	
MBL	
BLC	
SP-	
SP+	
SP+	
SB	
SB	

J700

6 O FNC1	11 O
1 O SB	FNC6
7 O FNC2	5 C
2 O	12 O
8 O FNC3	5 C
3 O PA	13 O
9 O FNC4	HR1
4 O DETO	14 O
10 O FNC5	HR2
5 O DATA1	15 O
DATA1	GND

EXTERNAL D-SUB 15PIN

CN700

OPT1	SI	CK	USEL	GND	AI	GND	STON	TCTL	AUDIH	TXO	RXEI	OPT6
1 O	3 O	5 O	7 O	9 O	11 O	13 O	15 O	17 O	19 O	21 O	23 O	25 O
2 O	4 O	6 O	8 O	10 O	12 O	14 O	16 O	18 O	20 O	22 O	24 O	26 O
OPT3	SO	OPT4	OPT5	GND	A0	5 C	DTI	NC	OPT2	RXE0	TXI	9 C

OPTION

FNC1	FNC4
FNC2	FNC5
FNC3	FNC6

OPTION